

# K.2 Series

**QSC**<sup>®</sup>

## User Manual

---

K8.2 – 105° 2000 W active 8-in (200 mm) 2-way loudspeaker system

K10.2 – 90° 2000 W active 10-in (250 mm) 2-way loudspeaker system

K12.2 – 75° 2000 W active 12-in (300 mm) 2-way loudspeaker system

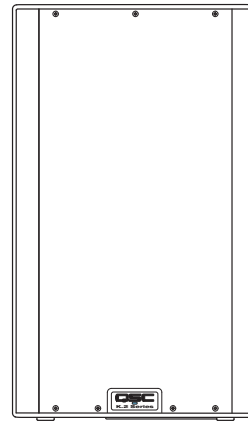
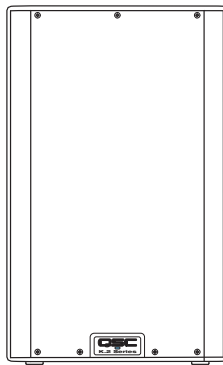
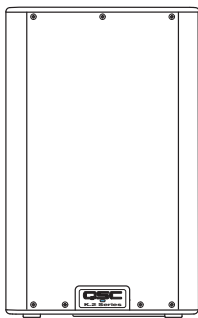

TD-000523-01-G



## EXPLANATION OF SYMBOLS

The term “WARNING!” indicates instructions regarding personal safety. If the instructions are not followed the result may be bodily injury or death.

The term “CAUTION!” indicates instructions regarding possible damage to physical equipment. If these instructions are not followed, it may result in damage to the equipment that may not be covered under the warranty.

The term “IMPORTANT!” indicates instructions or information that are vital to the successful completion of the procedure.

The term “NOTE” is used to indicate additional useful information.



**NOTE:** The intent of the lightning flash with arrowhead symbol in a triangle is to alert the user to the presence of un-insulated “dangerous” voltage within the product’s enclosure that may be of sufficient magnitude to constitute a risk of electric shock to humans.



**NOTE:** The intent of the exclamation point within an equilateral triangle is to alert the user to the presence of important safety, and operating and maintenance instructions in this manual.



### IMPORTANT SAFETY INSTRUCTIONS



**WARNING!:** TO PREVENT FIRE OR ELECTRIC SHOCK, DO NOT EXPOSE THIS EQUIPMENT TO RAIN OR MOISTURE. DO NOT USE THIS APPARATUS NEAR WATER.

1. Read these instructions.
2. Keep these instructions.
3. Heed all warnings.
4. Follow all instructions.
5. Do not use this apparatus near water.
6. Clean only with a dry cloth.
7. Do not block any ventilation opening. Install in accordance with the manufacturer’s instructions.
8. Do not install near any heat sources such as radiators, heat registers, stoves, or other apparatus (including amplifiers) that produce heat.
9. Do not defeat the safety purpose of the polarized or grounding-type plug. A polarized plug has two blades with one wider than the other. A grounding type plug has two blades and a third grounding prong. The wide blade or the third prong are provided for your safety. If the provided plug does not fit into your outlet, consult an electrician for replacement of the obsolete outlet.
10. Protect the power cord from being walked on or pinched particularly at plugs, convenience receptacles, and the point where they exit from the apparatus.
11. Only use attachments/accessories specified by the manufacturer.
12. Unplug this apparatus during lightning storms or when unused for long periods of time.
13. Refer all servicing to qualified service personnel. Servicing is required when the apparatus has been damaged in any way, such as power-supply cord or plug is damaged, liquid has been spilled or objects have fallen into the apparatus, the apparatus has been exposed to rain or moisture, does not operate normally, or has been dropped.

14. The appliance coupler, or the AC Mains plug, is the AC mains disconnect device and shall remain readily operable after installation.
15. Adhere to all applicable, local codes.
16. To prevent electrical shock, the power cord shall be connected to a mains socket outlet with a protective earthing connection.
17. Consult a licensed, professional engineer when any doubt or questions arise regarding a physical equipment installation.
18. Do not use any aerosol spray, cleaner, disinfectant or fumigant on, near or into the apparatus. Clean only with a dry cloth.
19. Do not unplug the unit by pulling on the cord, use the plug.
20. Do not submerge the apparatus in water or liquids.
21. Keep ventilation opening free of dust or other matter.

## Warranty

For a copy of the QSC Limited Warranty, visit the QSC website at [www.qsc.com](http://www.qsc.com)

## Maintenance and Repair



**WARNING!:** Advanced technology, e.g., the use of modern materials and powerful electronics, requires specially adapted maintenance and repair methods. To avoid a danger of subsequent damage to the apparatus, injuries to persons and/or the creation of additional safety hazards, all maintenance or repair work on the apparatus should be performed only by a QSC authorized service station or an authorized QSC International Distributor. QSC is not responsible for any injury, harm or related damages arising from any failure of the customer, owner or user of the apparatus to facilitate those repairs.

**Life Cycle:** 10 years, **Storage Temperature range:** -20C to +70C, **Relative Humidity range:** 5 - 85% RH

## FCC Statement



**NOTE:** This equipment has been tested and found to comply with the limits for a Class B digital device, pursuant to Part 15 of the FCC Rules.

These limits are designed to provide reasonable protection against harmful interference in a residential installation. This equipment generates, uses and can radiate radio frequency energy and, if not installed and used in accordance with the instructions, may cause harmful interference to radio communications. However, there is no guarantee that interference will not occur in a particular installation. If this equipment does cause harmful interference to radio or television reception, which can be determined by turning the equipment off and on, the user is encouraged to try to correct the interference by one or more of the following measures:

- Reorient or relocate the receiving antenna.
- Increase the separation between the equipment and receiver.
- Connect the equipment into an outlet on a circuit different from that to which the receiver is connected.
- Consult the dealer or an experienced radio/TV technician for help.

## RoHS Statements





These products are in compliance with European Directive 2011/65/EU – Restriction of Hazardous Substances (RoHS).

These products are in compliance with “China RoHS” directives per GB/T26572. The following table is provided for product use in China and its territories:

部件名称 (Part Name)	These products 这些产品					
	有害物质 (Hazardous Substances)					
	铅 (Pb)	汞 (Hg)	镉 (Cd)	六价铬 (Cr(vi))	多溴联苯 (PBB)	多溴二苯醚 (PBDE)
电路板组件 (PCB Assemblies)	X	O	O	O	O	O
机壳装配件 (Chassis Assemblies)	X	O	O	O	O	O

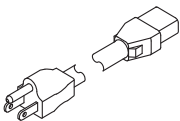
本表格依据 SJ/T 11364 的规定编制。(This table is prepared following the requirement of SJ/T 11364.)  
 O: 表示该有害物质在该部件所有均质材料中的含量均在 GB/T 26572 规定的限量要求以下。  
 O: Indicates that the concentration of the substance in all homogeneous materials of the part is below the relevant threshold specified in GB/T 26572.  
 X: 表示该有害物质至少在该部件的某一均质材料中的含量超出 GB/T 26572 规定的限量要求。  
 X: Indicates that the concentration of the substance in at least one of all homogeneous materials of the part is above the relevant threshold specified in GB/T 26572.  
 (目前由于技术或经济的原因暂时无法实现替代或减量化) (Replacement and reduction of content cannot be achieved currently because of the technical or economic reason.)

## Package Contents

	1 K.2 Series Loudspeaker		1 Locking AC Power cord		1 White QSC Logo
	1 QSC Limited Warranty TD-000453		1 K.2 Series Quick Start Guide TD-000452		1 Powered Loudspeaker Safety Sheet TD-000337

## Features

### K8.2

1. ABS enclosure
2. Steel grille
3. Front power LED
4. Cast aluminum handle
5. Power module
6. M10 installation points
7. M8 yoke-attachment points
8. 7.5° Downward-tilt pole socket
9. Vertical pole socket
10. Pull-back ring
11. Slip-resistant feet for floor monitor applications
12. Angled back for use as a stage monitor

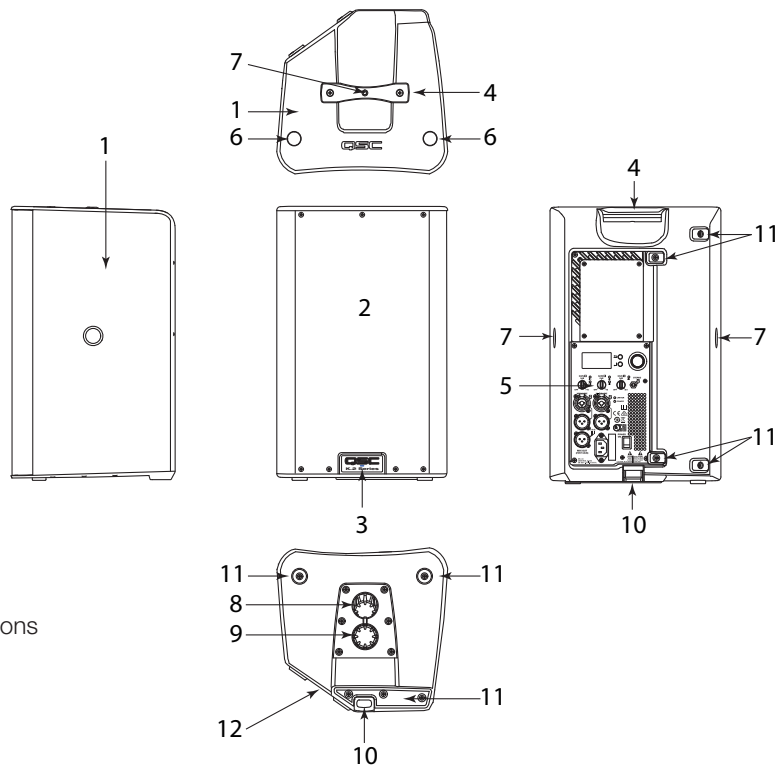

— Figure 1 —

### K10.2

1. ABS enclosure
2. Steel grille
3. Front power LED
4. Cast aluminum handles
5. Power module
6. M10 installation points
7. M8 yoke attachment points
8. 7.5° Downward-tilt pole socket
9. Vertical pole socket
10. Pull-back ring
11. Slip-resistant feet
12. Angled back for use as a stage monitor

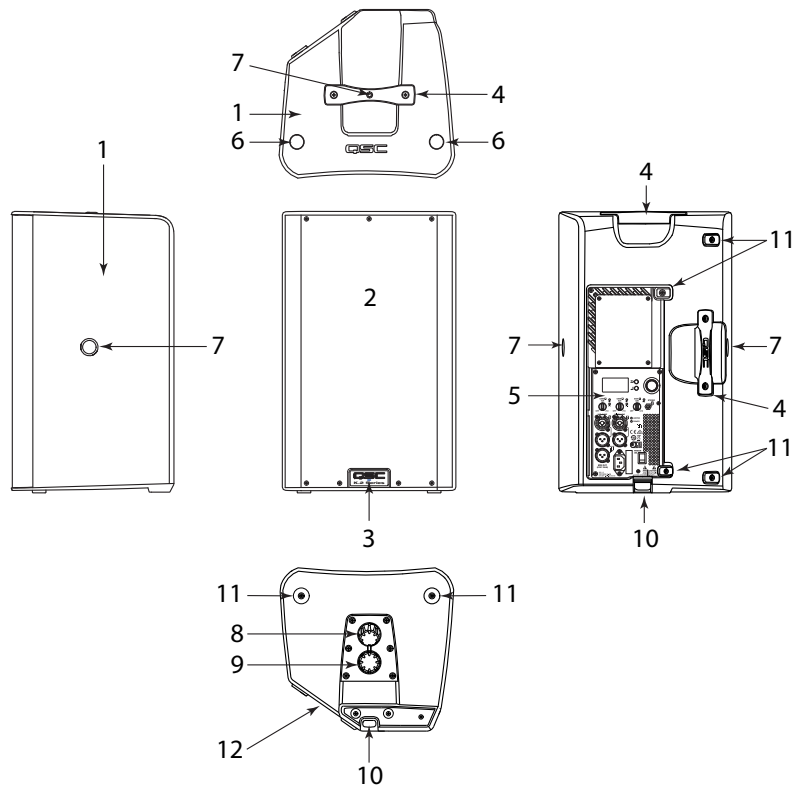

— Figure 2 —

## K12.2

1. ABS enclosure
2. Steel grille
3. Front power LED
4. Cast aluminum handles
5. Power module
6. M10 installation points
7. M8 yoke attachment points
8. 7.5° Downward-tilt pole socket
9. Vertical pole socket
10. Pull-back ring
11. Slip-resistant feet
12. Angled back for use as a stage monitor

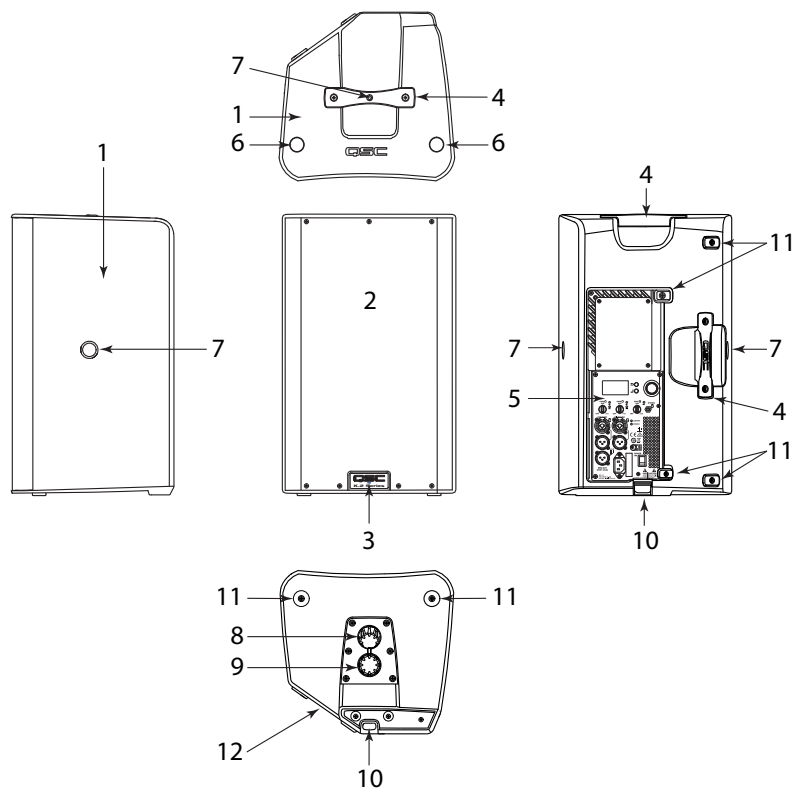

— Figure 3 —

## Applications

The K.2 Series has been primarily designed for portable audio reinforcement. This includes a variety of uses in reinforcement for entertainers and presenters. All are designed to perform well on their own in full-range audio. They can be used singly, in stereo pairs or in distributed or delayed systems. They perform extraordinarily well as both main reinforcement systems and as floor monitors as shown in Figure 4.

All three models are equipped with two 35 mm pole sockets that allows use on a speaker stand or on a pole over a subwoofer. (The subwoofer must have a 35 mm pole socket capable of supporting the loudspeakers.) One socket is for vertical mounting, the other for tilting the enclosures down 7.5 degrees. (Refer to Figure 5)

In addition, the K.2 Series have features designed for various suspension methods. They feature two M10 threaded inserts for suspension with eyebolts and a built-in pull-back ring. There are also yoke accessories (model numbers: K8.2 YOKE, K10.2 YOKE, K12.2 YOKE) for each model that can mount either to the sides of the cabinet or to the top and bottom. These yokes allow for rigid mounting to structures and rotation of the speaker system. (Refer to Figure 6 and Figure 7)

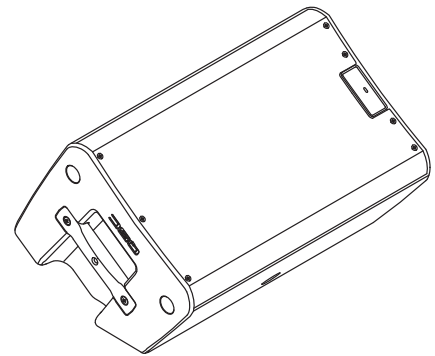

— Figure 4 —

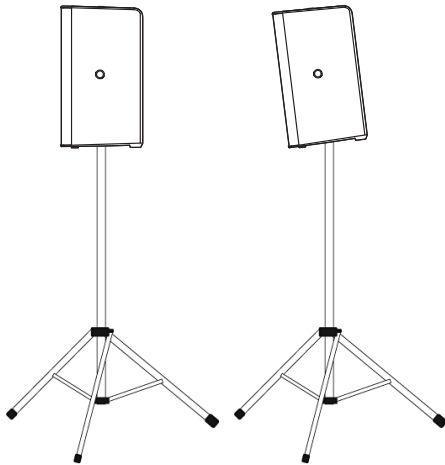

— Figure 5 —

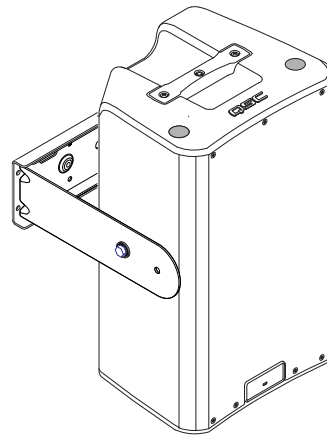

— Figure 6 —

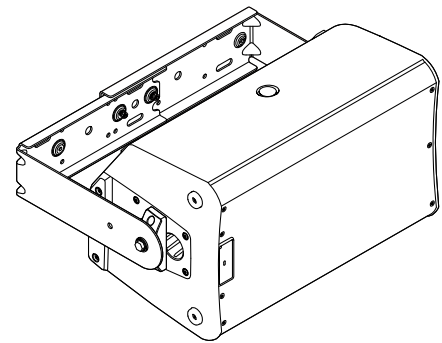

— Figure 7 —

## Installation



**WARNING!** Before placing, installing, rigging, or suspending any speaker product, inspect all hardware, suspension, cabinets, transducers, brackets and associated equipment for damage. Any missing, corroded, deformed, or non-load rated component could significantly reduce the strength of the installation or placement. Any such condition severely reduces the safety of the installation and should be immediately corrected. Use only hardware which is rated for the loading conditions of the installation and any possible short-term, unexpected overloading.

Never exceed the rating of the hardware or equipment.

Consult a licensed, professional engineer regarding physical equipment installation. Ensure that all local, state and national regulations regarding the safety and operation of loudspeakers and related equipment are understood and adhered to.

## Deployment

The **K.2 Series** loudspeakers were designed to sit on the floor, stage, a subwoofer enclosure, be suspended, or be pole mounted on a 35 mm diameter loudspeaker support pole. If you are going to pole-mount on a subwoofer, refer to the chart below for specifics.



**WARNING!:** Do not use a loudspeaker support pole longer than the lengths specified in the table below when supported by a subwoofer.

K.2 Series	Subwoofers		
	KS212C	KW181	KSUB
K8.2	36 in (914 mm)	36 in (914 mm)	31 in (787 mm)
K10.2	36 in (914 mm)	36 in (914 mm)	28.5 in (724 mm)
K12.2	36 in (914 mm)	36 in (914 mm)	26.5 in (673)

### Integrated Suspension Points (suspended installations)

Refer to TD-000289 for M10 eye bolt installation.

The **K8.2**, **K10.2** and **K12.2** enclosures each feature two load-rated M10 installation points and a built-in pull-back ring.

As shipped from the factory, each pick point has a adhesive cover installed to retain the sleek look of the enclosure. These installation points are designed for use with the eyebolts included in the available accessory kit, model number M10 Kit-C. The installation points may also be used with any forged shoulder eyebolt with an M10 thread, provided the length of the thread is no more than 0.8 inch (20 mm).



**WARNING!:** Make sure all suspension-point fasteners are installed and correctly tightened in order to maintain enclosure's rated strength.

Consult a licensed, professional engineer when any doubt or questions arise regarding a physical equipment installation.

The K.2 Series loudspeakers each have two M10 suspension points, and one pull-back ring.

1. M10 suspension points
2. Pull-back ring

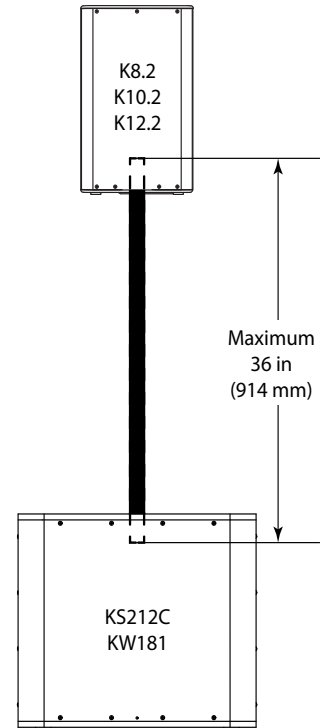

— Figure 8 —

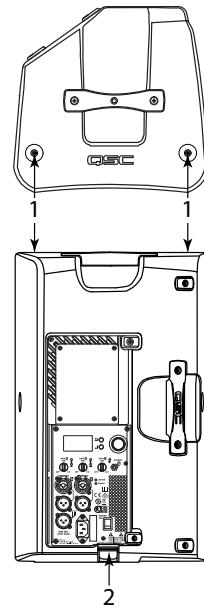

— Figure 9 —

## Cooling

This is a powered loudspeaker containing an internal power amplifier that produces heat. Allow a minimum of 6" (152 mm) clearance at cabinet back for convection cooling. Keep anything that might restrict airflow away from the rear of the enclosure (i.e. draperies, walls, etc.)



**CAUTION!** Do not install enclosures with their rear panels exposed to direct sunlight. Direct sunlight will heat the amplifier module and reduce its ability to produce full output. Install sunshades if needed. Maximum ambient temperature for full performance to specification is 50° C (122° F). Do not install enclosures where exposed to rain or other water sources. The enclosure is not weatherproof. Outdoor installations must provide protection from the elements.

## AC Mains

Refer to Figure 10)

Connect the AC power cord to the IEC socket on the back of the amplifier. Make sure the plug is fully inserted into the IEC socket on the power amplifier module.



**NOTE:** Make sure that the AC power switch is in the OFF position before connecting AC power cord to the AC source.

Connect the AC Power cord to the facility's AC outlet.

The V-LOCK power cord has a special latching feature to prevent the power cord from being unintentionally removed. The IEC plug and socket are both blue in color so the power cord can be identified as a K.2 Series loudspeaker cord. If the QSC-supplied cord is lost or damaged, a standard 18-gauge IEC power cord may be used. However, the latching system works only with a V-LOCK power cord. Available from QSC.

The K.2 Series loudspeakers are equipped with a universal power supply that can use input AC power voltages ranging from 100 – 240 VAC at 50 – 60 Hz.

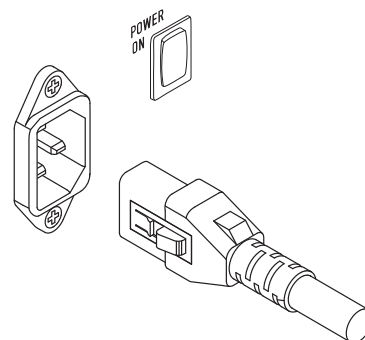

— Figure 10 —



**WARNING!** Use only the power cable that is correct for your location.

### AC Mains Disconnection

Push in on the bottom of the rocker switch to turn the powered loudspeaker off. Unplug the AC cable from the power source. To remove the AC mains cord from the amplifier, grasp the IEC connector's plastic body, press the yellow latch release button and pull.

### Power Switch

Push in on the top of the rocker switch to apply AC mains power to the amplifier. When power is applied to the amplifier, the blue POWER indicator LED illuminates.

### Rear LED POWER Indicator

The blue LED POWER indicator on the rear panel will illuminate when the AC Power is applied. The rear LED POWER indicator will extinguish when the AC Power has been removed.

If the rear LED POWER indicator does not illuminate within the first 3 minutes after power is applied, verify the AC mains line cord is properly attached to the loudspeaker and plugged into the AC outlet. Verify the outlet is functioning properly.



**NOTE:** If the AC mains cord is usable and the AC mains outlet is operating properly, but the unit fails to operate, the loudspeaker may require servicing. Contact QSC's Technical Services department.

## System Power Sequencing

Proper power turn on/turn off sequencing can help to prevent unexpected sounds from being produced by the system (pops, clicks, thumps). Always follow the rule that speakers are “last on, first off”.

Power On Sequence: Bring the output level control of the mixer (or other audio source) feeding your speakers to its minimum position. Turn on all source devices (CD players, mixers, instruments), turn on subwoofer, then turn on the “top-boxes” ( **K8.2**, **K10.2** and **K12.2**). The level controls on your mixer may now be brought up.

Power Off Sequence: Turn off “top boxes,” turn off subwoofer, then turn off all source devices.

If a K.2 Series speaker is being driven from the output of another K.2 Series unit, it should be turned on after the unit feeding it signal, and turned off before the unit feeding it signal.

## Block Diagram

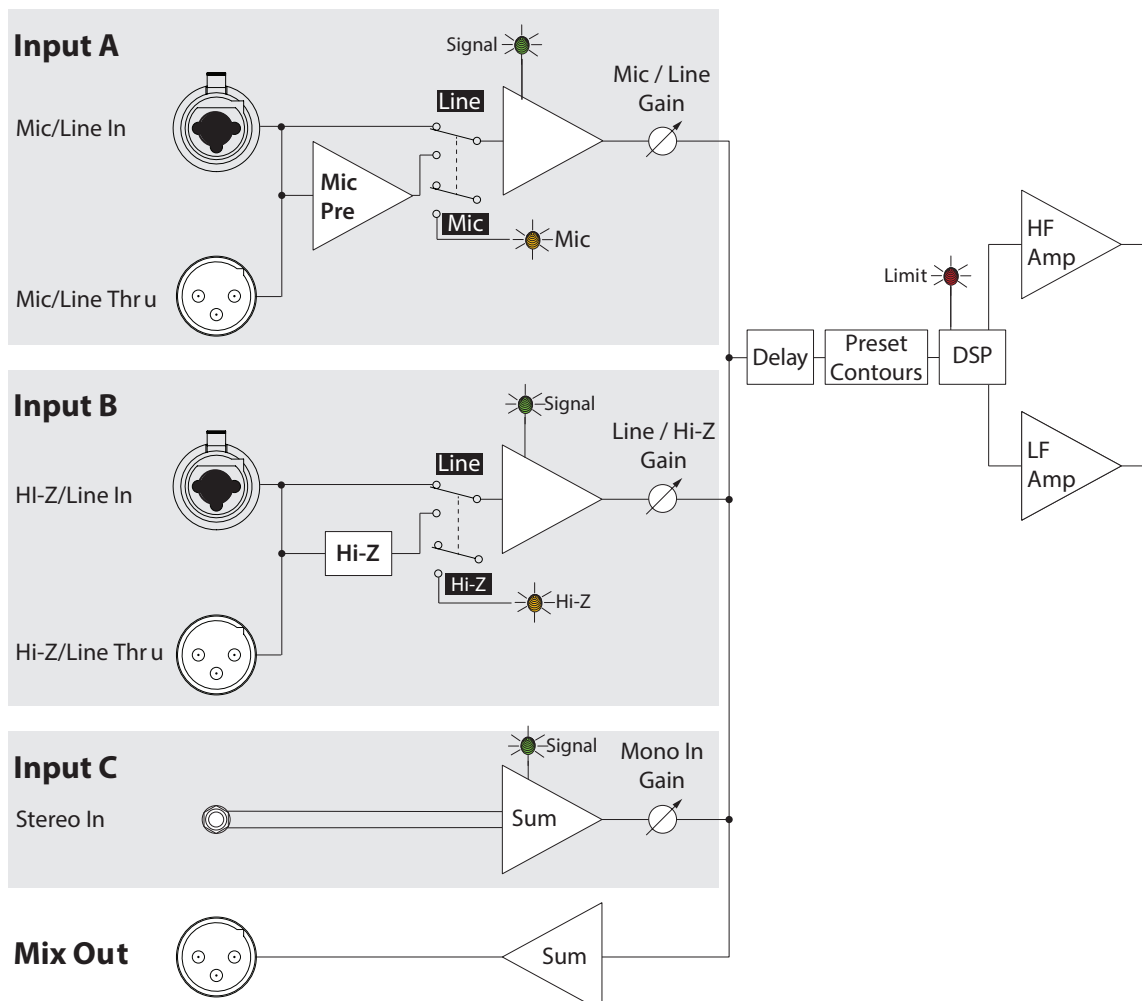

— Figure 11 —

## Inputs

The K.2 Series amplifier has three separate inputs; two combination XLR / 1/4" Phone Jack (Inputs A and B) and one 1/8" (3.5 mm) TRS jack (Input C).

Refer to Figure 12

### 1. Input A

- SIG** LED – When illuminated (green), it indicates a signal is present. If this LED is not illuminated, the input signal is missing or too low to detect.
- MIC** LED – When illuminated (yellow) it indicates the input is configured to accept a microphone input. When not illuminated, it indicates the input is configured for a line-level input. You can change the setting through the Menu. When MIC is selected, the MIC Pre-amp is activated, and the yellow MIC level LED illuminates. The MIC setting should only be used if a microphone is connected directly to the MIC/LINE input. Note that the input does not provide phantom power.
- GAIN** knob – Sets the sensitivity of Input A which controls the signal level sent to the amplifier and the MIX OUT (POST GAIN) output.
- Combination XLR – 1/4" Phone Jack** connector. Balanced XLR and 1/4" input. Accepts line-level or MIC-level inputs. Select MIC or Line through the Menu.



**CAUTION!** The MIC setting should only be used if a microphone is connected directly to the MIC/LINE input. Using the MIC setting for line-level may introduce distortion. Use caution when changing to the MIC selection in the Menu as the output level increases significantly when MIC is selected.

### 2. Input B

- GAIN** knob – Sets the sensitivity of Input B which controls the signal level sent to the amplifier and the MIX OUT (POST GAIN) output.
- SIG** LED – When illuminated (green), it indicates a signal is present. If this LED is not illuminated, the input signal is missing or too low to detect.
- HI-Z** LED – When illuminated (yellow) it indicates the input is configured to accept a high impedance input, typically a musical instrument. When not illuminated, it indicates the input is configured for a line-level input. You can change the setting through the Menu.
- Combination XLR – 1/4" Phone Jack** connector. Balanced XLR and 1/4" input. Accepts line-level and high Impedance inputs. Select line level or high impedance through the Menu.

### 3. Input C

- GAIN** knob – Sets the sensitivity of Input C which controls the signal level sent to the amplifier and the MIX OUT (POST GAIN) output.
- SIG** LED – When illuminated (green), it indicates a signal is present. If this LED is not illuminated, the input signal is missing or too low to detect.
- Stereo 1/8" (3.5 mm) TRS** connector – Accepts line-level stereo input. Stereo input received at Input C is summed to mono.

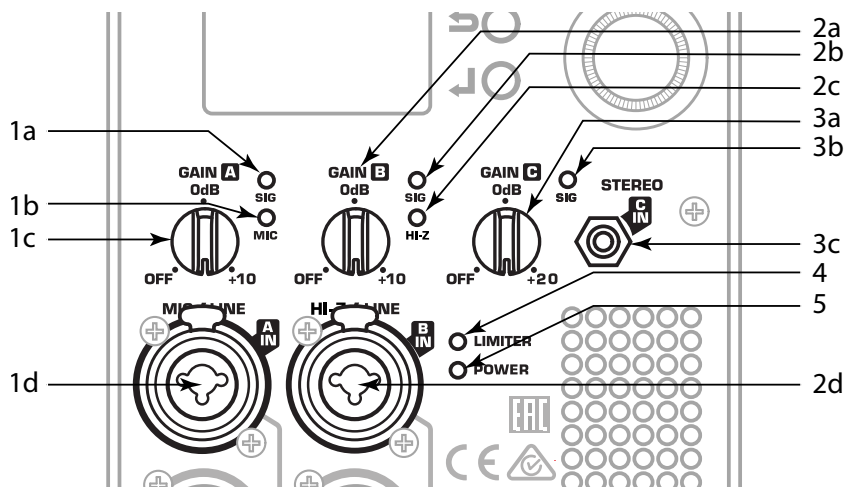

— Figure 12 —

4. **LIMITER** LED – Illuminates (red) when the built-in limiter is activated to protect and avoid damage to the amplifier or loudspeaker. If the signal level at any frequency is too high, or the amplifier is too hot, the limiter is activated and the LED is illuminated.
5. **POWER** LED – Illuminates (blue) when power is applied to the unit and the ON/OFF switch is in the ON position.



**NOTE:** Unless the gain controls of all active inputs are set to 0 dB, the output signal from the MIX OUT (POST GAIN) will not be at the same level as the input signal. If a “slave” speaker is intended to playback at the same level as the “master” speaker, the gain control on the “slave” speaker should be set to 0 dB.

### Balanced Inputs

Connect the XLR plug as shown in Figure 13.

1.  Shield (ground)
2.  Positive
3.  Negative

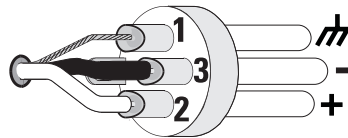

— Figure 13 —

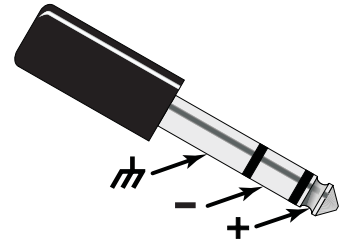

— Figure 14 —

Connect the TRS plug as shown in Figure 14. Do not use a TS 1/4” jack for balanced input.

1.  Shield (ground)
2.  Negative
3.  Positive

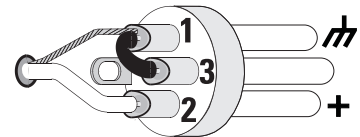

— Figure 15 —

### Unbalanced Inputs

Connect the XLR plug as shown in Figure 15. (Jumper pins 1 and 3.)

1.  Shield (ground)
2.  Positive
3.  Negative

Connect the TRS or TS plug as shown in Figure 16.

1.  Shield (ground)
2.  Negative
3.  Positive

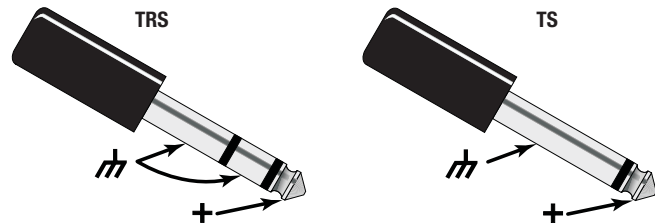

— Figure 16 —

## Outputs

1. Channel B pass-through output connector. The signal here is the same as the input signal on Channel B. Use this to daisy-chain loudspeakers or to provide the signal to other audio equipment.
2. Channel A pass-through output connector. The signal here is the same as the input signal on Channel A. Use this to daisy-chain loudspeakers or to provide the signal to other audio equipment.

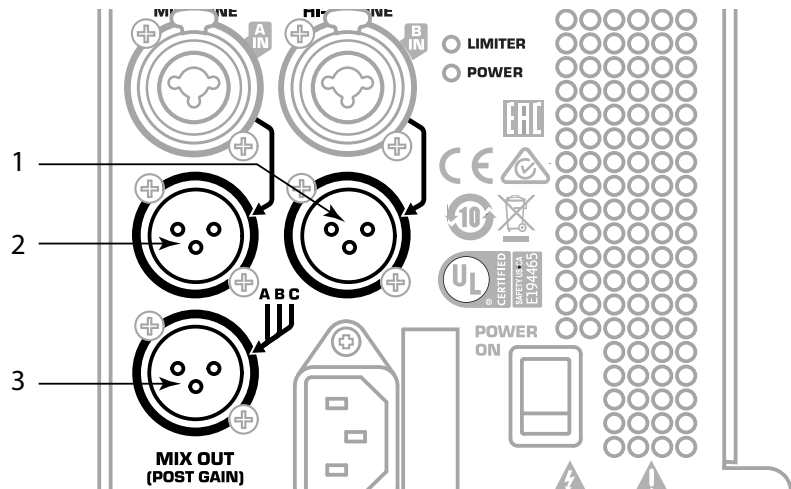

— Figure 17 —

3. **MIX OUT (Post Gain)** output XLR is a mix of Channels A, B, and C. The line-level output signal is Post Gain. Any adjustments made to the gain of any of the three channels affects this output signal. This output does not contain any DSP processing.



**CAUTION!** Do not connect the MIX OUT (Post Gain) of a K.2 Series loudspeaker to any INPUT of the **same unit**. This output is designed to send the mixed signal to OTHER K.2 Series units or to other audio equipment.

## K.2 Series Menu

The K.2 Series loudspeakers provide a multi-function digital display for control and selection of loudspeaker functions including presets, scenes, cross-over, EQ, delay and frequency contour.

### Display Introduction

1. **Home Screen** – Displays input types (MIC, Line, HI-Z) for channels A and B, and main functionality headings. Light background with black text indicates the item is selected.
2. **Exit**, or go back button – press to return to the previous screen or menu level.
3. **Enter** button – confirm a selected parameter or open the selected menu item.
4. **Selector** knob – move to another menu item, or change a selected parameter.
5. Left side, Home screen displays the parameter name.
6. Right side, Home screen displays the current state of the parameter.

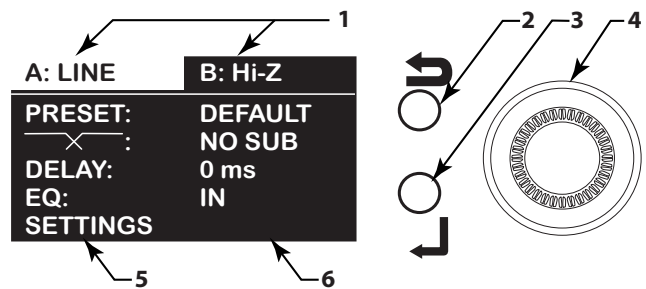

— Figure 18 —

### Navigation Example:

To select a Preset:



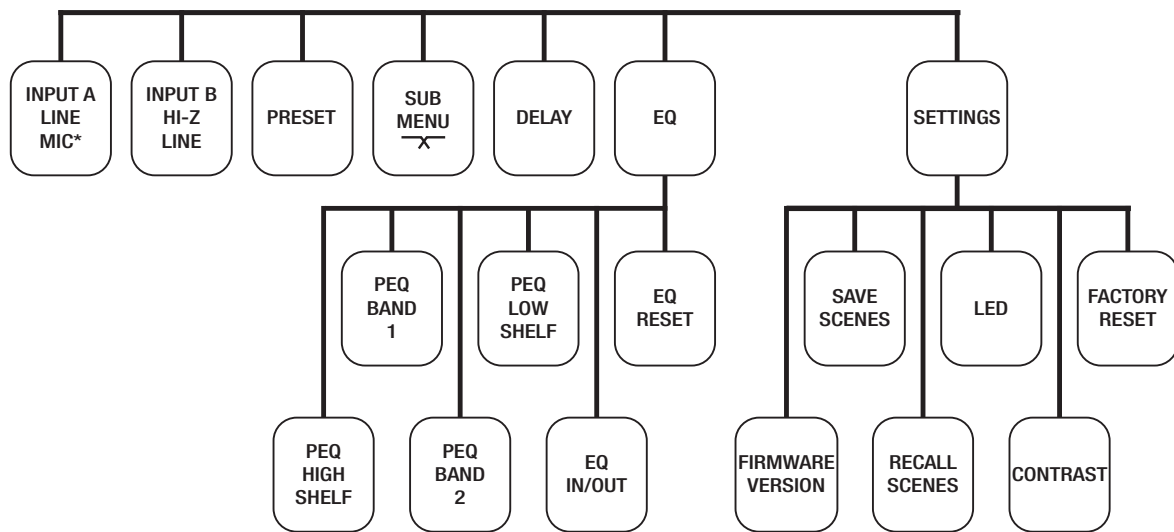

1. Turn the Selector knob (4) clockwise to highlight the PRESET line.
2. Press the Enter button (3) to access the PRESET submenu.
3. Turn the Selector knob (4) clockwise or counterclockwise as needed to highlight the PRESET you wish to recall.
4. Press the Enter button (3) to recall the PRESET. A small triangle displays next to the recalled (active) PRESET.
5. Press the Exit button (2) to return to the Home screen.

## Menu Map



— Figure 19 —

## Menu Listing

<b>INPUT A: Select the sensitivity of input A</b>		
LINE		Use with mixers and other sources that have high-level outputs.
MIC		Use with directly connected microphones and sources with low-level output.
<b>INPUT B: Select the sensitivity and impedance of input B</b>		
LINE		Use with mixers and other sources that have high-level outputs.
INST		Use when connecting musical instruments with passive pick-up systems.

**PRESETS**      **Select a pre-programmed EQ and dynamic processing setting for specific applications**

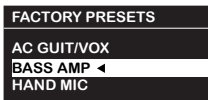
Factory Presets Example		Use the Selector knob to scroll (up or down) to the Preset you wish to recall.
-------------------------	---	--

DEFAULT	The basic voicing of the loudspeaker
LIVE	For live sound reinforcement and vocal clarity
LIVE BRIGHT	Similar to LIVE with some high-frequency boost to balance the sub
DANCE	Low and high frequency emphasis
STAGE MONITOR 1	For most stage monitor uses, reduces excessive bass build-up on stage
STAGE MONITOR 2	For stage monitor use when low frequency reproduction is needed
AC GUIT / VOX	For Acoustic Guitars and VOX
BASS AMP	For direct connection of bass instruments
HAND MIC	For speech intelligibility and feedback reduction using a hand-held microphone.
HEAD MIC	For speech intelligibility and feedback reduction using a head microphone.
STUDIO MON	For use as a recording monitor

**SUB MENU**      **Select a setting to match the top-box with a subwoofer**

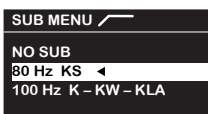
SUB Menu Example		<p>In the example, the 80 Hz KS high-pass filter is selected. Use the Selector knob to scroll to the filter you need, then press the Enter button.</p> <p><b>NOTE:</b> All crossovers share the same phase – the only time alignment to make is compensating for the actual distance between sub and top boxes</p>
------------------	---	--

NO SUB	For use without a subwoofer
80 Hz KS	Applies an 80 Hz High Pass Filter (HPF)

100 Hz K – KW – KLA	Applies a 100 Hz High Pass Filter (HPF) (For use with a K-SUB, KW Sub, or KLA Sub)
125 Hz	Applies a 125 Hz High Pass Filter (HPF)

**DELAY** Adjust the signal delay for rear fill and similar applications.

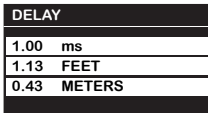
Delay		0 –100 milliseconds, 0 – 113 feet, 0 – 34 meters
	1.13 FEET	All units of measure change together when the Selection knob is turned.
	0.43 METERS	

**EQ** Adjust the 4-band, parametric equalizer

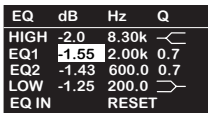
EQ Example		In the example, EQ1 is selected. Press the Enter button to adjust. When you are finished, press the Enter button to make the change, or the Exit button to exit without changing the parameter.
	HIGH -2.0 8.30k	
	EQ1 1.55 2.00k 0.7	
	EQ2 -1.43 600.0 0.7	
	LOW -1.25 200.0	
EQ IN	RESET	

	dB	Hz	Q
High Shelving Band Default	0.0 dB to -6.0 dB 0.0 dB	1.0 kHz to 10.0 kHz 8.0 kHz	N/A
EQ1 (EQ for Band 1) Default	0.0 dB to -6.0 dB 0.0 dB	50 Hz to 20.0 kHz 1.0 kHz	0.4 to 4.0 0.7
EQ2 (EQ for Band 2) Default	0.0 dB to -6.0 dB 0.0 dB	200 Hz to 20 kHz 1.0 kHz	0.4 to 4.0 0.7
Low Shelving Band Default	0.0 dB to -6.0 dB 0.0 dB	100 Hz to 500 Hz 100 Hz	N/A
EQ IN/OUT	Engages / bypasses the equalizer		
RESET	Returns the EQ to the flat, default settings		

**SETTINGS** Utility Functions

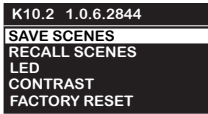
Displays firmware version and other menu selections		Displays the firmware version number – cannot edit this field. Depending on the loudspeaker model, K8.2, K10.2, or K12.2 displays next to the firmware version. Use the Selector knob to select the Utility you want, then press the Enter button.
---	---	--

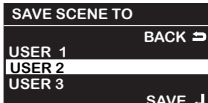
SAVE SCENES		Used to save the current speaker settings to one of five user presets
-------------	---	---

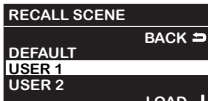
RECALL SCENES		Used to recall the factory default setting or one of the saved user scenes
---------------	---	--

LED		Selects which combination of front and rear LEDs illuminate
-----	---	---

CONTRAST		Adjusts the contrast of the LCD
----------	---	---------------------------------

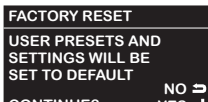
FACTORY RESET		Resets all parameters to the factory defaults, clears user presets – no undo.
---------------	---	---

# Hookup Diagrams

## Two Loudspeakers Daisy-chained

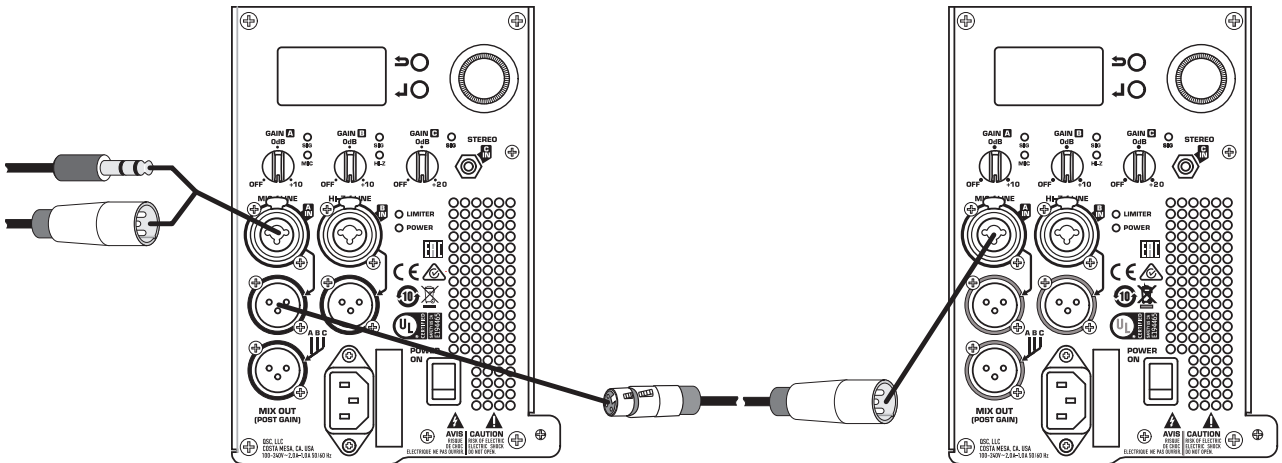

— Figure 20 —

## Typical Stereo System

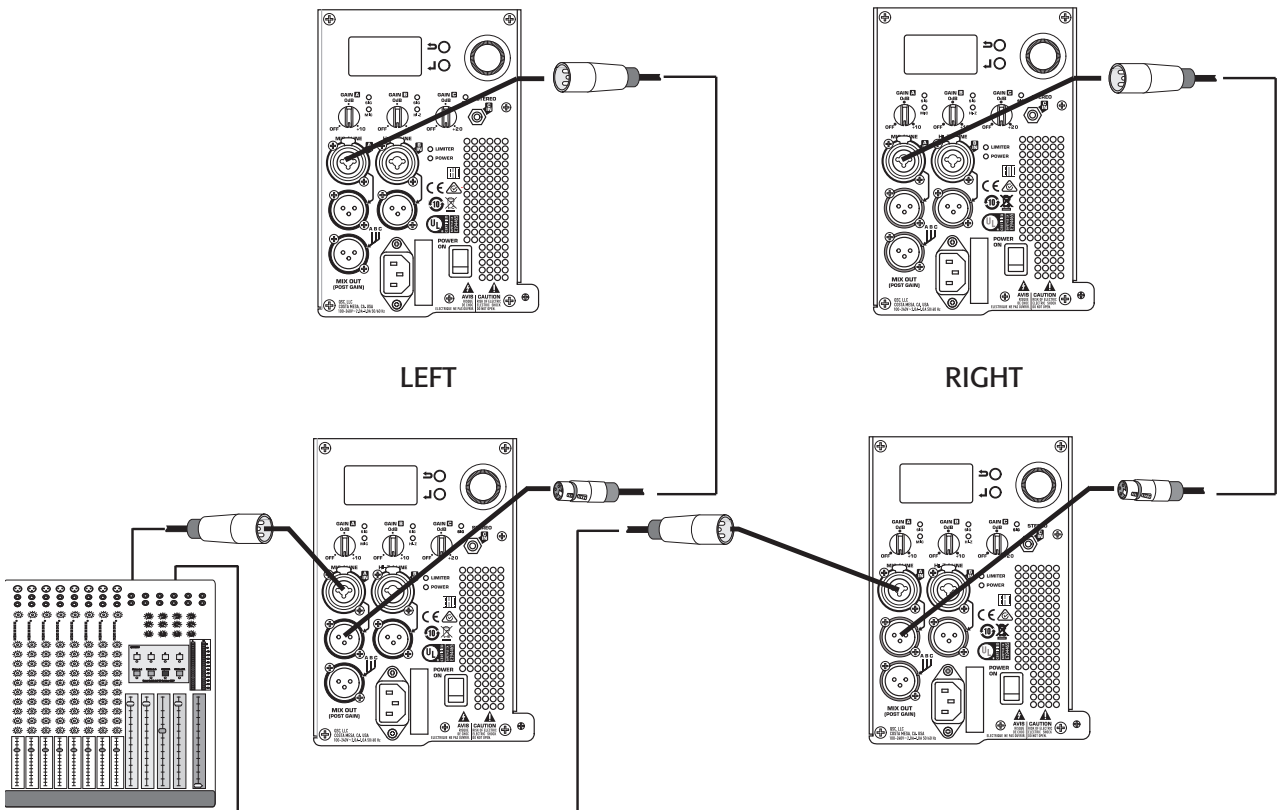

— Figure 21 —

# Standalone System

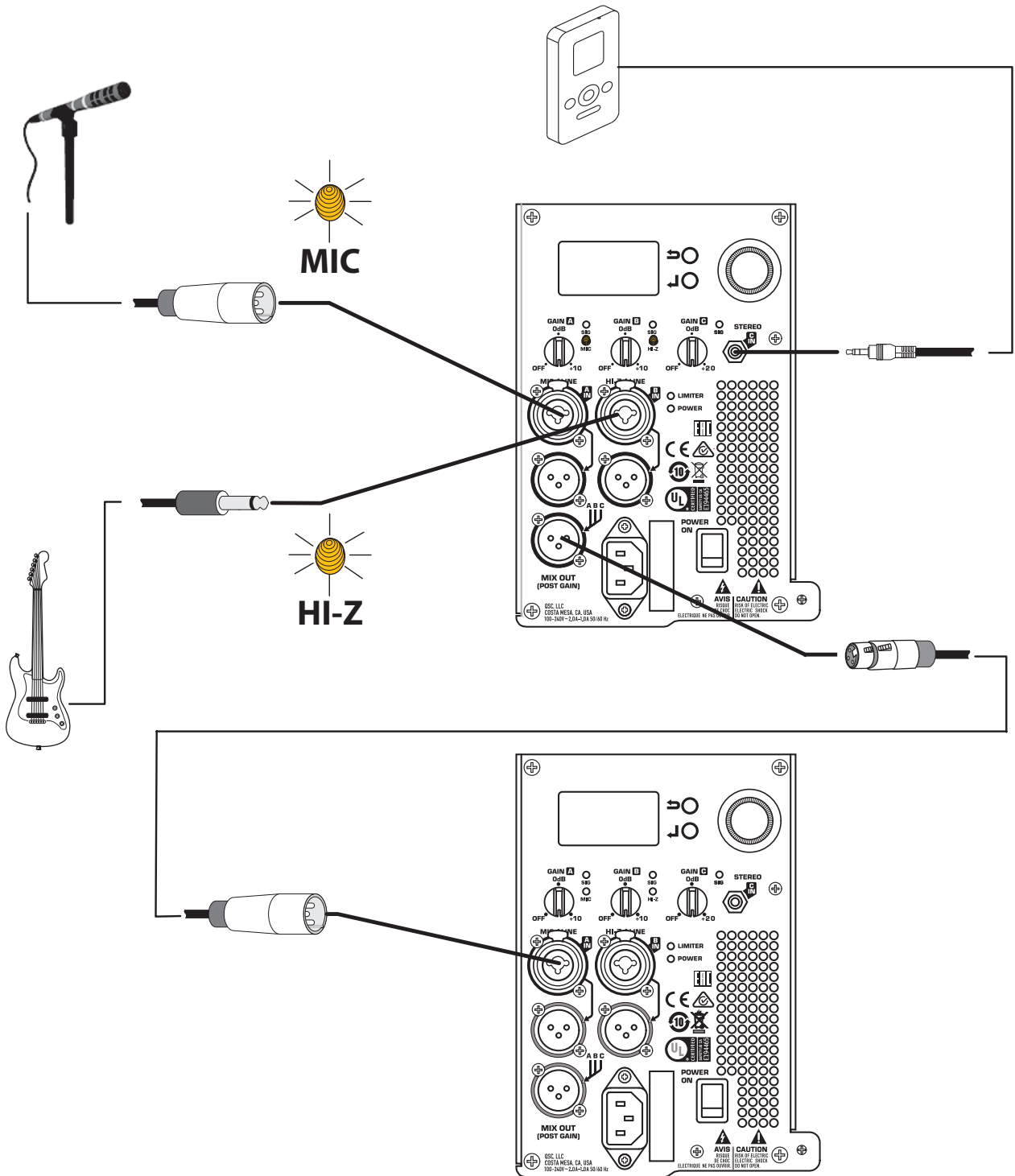

— Figure 22 —

## Dimensions

### K8.2 Loudspeaker

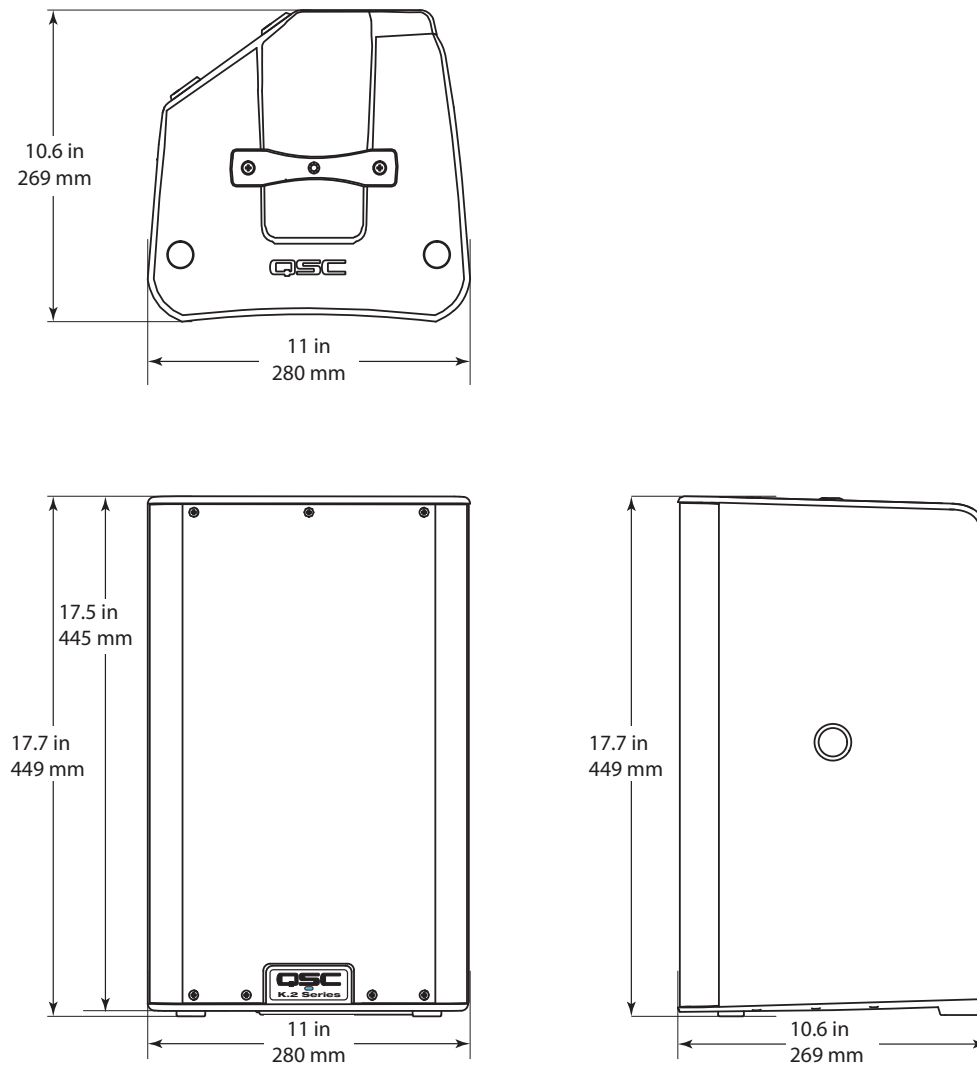

— Figure 23 —

# K10.2 Loudspeaker

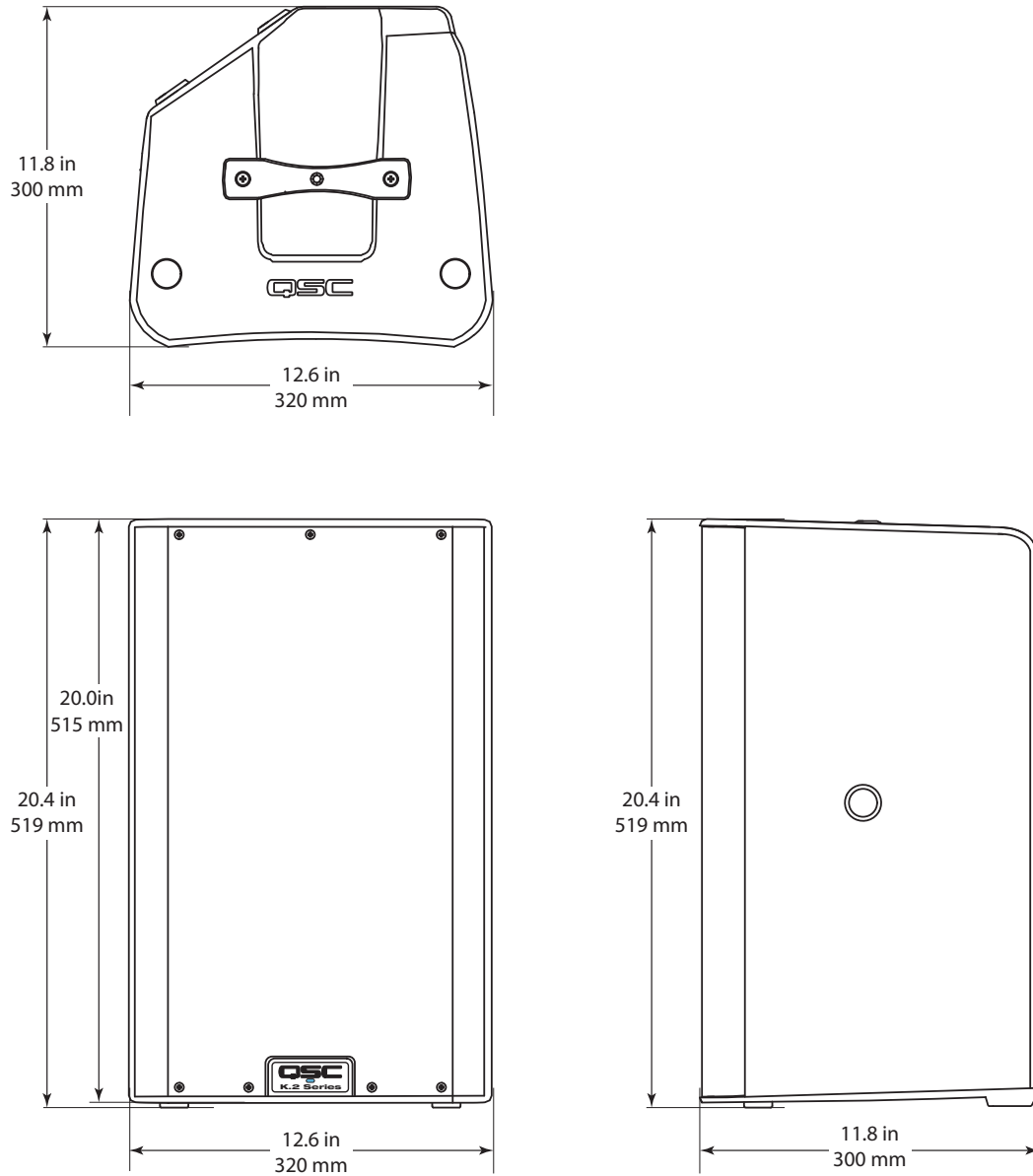

— Figure 24 —

# K12.2 Loudspeaker

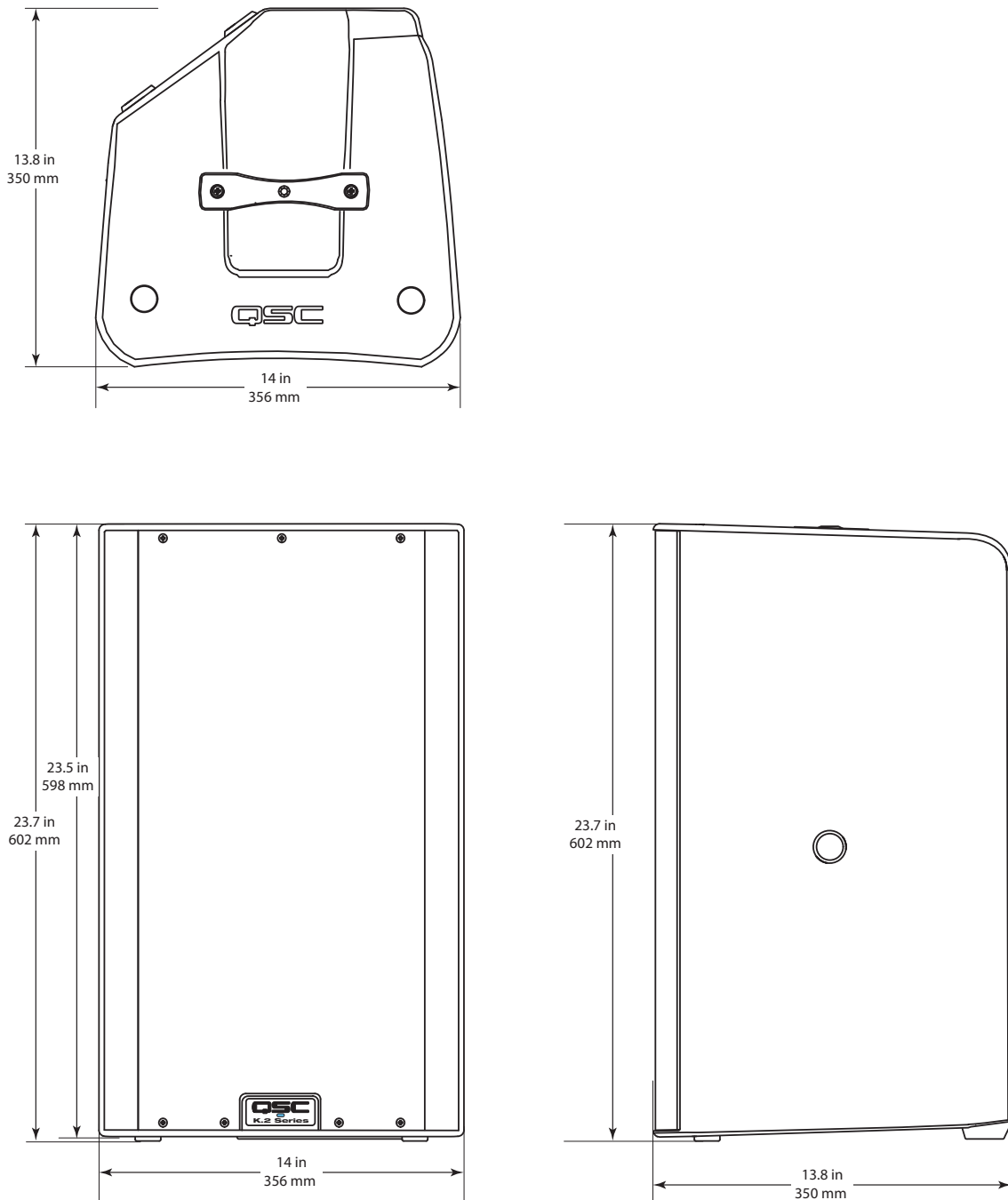

— Figure 25 —

## Specifications

	K8.2	K10.2	K12.2
Configuration:	Multi-purpose, 2-way powered loudspeaker		
LF Transducer:	8" (203 mm), cone	10" (254 mm), cone	12" (305 mm), cone
HF Transducer:	1.4" (35.6 mm) titanium diaphragm compression driver		
Frequency Response (-6 dB):	59 Hz - 20 kHz	56 Hz - 20 kHz	50 Hz - 20 kHz
Frequency Range (-10 dB):	55 Hz - 20 kHz	50 Hz - 20 kHz	45 Hz - 20 kHz
Nominal Coverage Angle:	105° Axisymmetric	90° Axisymmetric	75° Axisymmetric
Maximum Rated SPL <sup>1</sup> :	128 dB	130 dB	132 dB
Amplifier:	Class D Peak: 1800 W (LF), 225 W (HF)		
Cooling:	Low-noise, variable speed fan		
Controls:	Power 3 x Level 2 x selection buttons		
Indicators:	Monochrome LCD Display 1.75" x 1" (45 mm x 25.4 mm) 2 x Power LED (front and rear) 3 x Input Signal LED Input A MIC selected LED Input B HI-Z selected LED Limiter active LED		
Connectors:	2 x locking XLR/F ¼" combo (MIC/Line Input + HI-Z/Line Input) 1 x 3.5 mm TRS (Stereo Input) 2 x XLR/M (Loop-thru Output) 1 x XLR/M (Mix Output) 1 x locking IEC power connector		
AC Power Input:	Universal power supply 100 – 240 VAC, 50 – 60 Hz		
AC Power Consumption 1/8th Power:	100 VAC, 2.1 A 120 VAC, 1.9 A 240 VAC, 1.1 A		
Enclosure Details			
Enclosure:	Impact Resistant ABS		
Attachment Points:	2 x M10 threaded inserts plus Pull-back		
Color:	Black (RAL 9011)		
Grille:	18 Gauge powder coated steel, internal cloth lining		
Dimensions (HxWxD):	17.7 x 11 x 10.6 in 449 x 280 x 269 mm	20.4 x 12.6 x 11.8 in 519 x 320 x 300 mm	23.7 x 14 x 13.8 in 602 x 356 x 350 mm
Net Weight:	12.2 kg (27 lbs)	14.5 kg (32 lbs)	17.7 kg (39 lbs)
Shipping Weight:	14.4 kg (31.8 lbs)	17.6 kg (38.8 lbs)	21.7 kg (47.8 lbs)
Regulatory:	CE, WEEE, UL, China RoHS, RoHS II, FCC Class B		
Optional Accessories:	K8 Tote K8 Outdoor Cover M10 Kit-C K8.2 Yoke Pole, 35 mm, M20	K10 Tote K10 Outdoor Cover M10 Kit-C K10.2 Yoke Pole, 35 mm, M20	K12 Tote K12 Outdoor Cover M10 Kit-C K12.2 Yoke Pole, 35 mm, M20



**NOTE:** Specifications subject to change without notice.



### **QSC Self Help Portal**

Read knowledge base articles and discussions, download software and firmware, view product documents and training videos, and create support cases.

<https://qscprod.force.com/selfhelpportal/s/>

### **Customer Support**

Refer to the Contact Us page on the QSC website for Technical Support and Customer Care, including their phone numbers and hours of operation.

<https://www.qsc.com/contact-us/>