



ATND1061LK ATND1061DAN

Beamforming Array Microphone

IP Control Specifications (Document Version: 8.0)

Revision history

Date	Version	Description of change
2020/06/19	1.0	First edition
2022/05/24	2.0	<p>Changed the multicast address in 5.1.1.</p> <p>Changed Group ID and Internal ID to “Not used” in 4.5.37 and 4.5.38.</p> <p>Changed the command example in 4.5.37 and 4.5.38.</p>
2023/05/11	3.0	<p>Removed ATND-1061 notation and changed to ATND1061.</p> <p>3: Added page number to Command List.</p> <p>4.3.1, 4.3.2, 4.4.1, 4.4.2, 5.2.2, 5.2.3: Corrected “dB” notation in the table to “dB”.</p> <p>4.3.3, 4.3.4, 4.3.7, 4.3.8: Removed unnecessary values from the table.</p> <p>4.3.5, 4.3.6: Corrected typos in the table.</p> <p>4.3.11, 4.3.12: Corrected unnecessary parameters to “Reserved” and corrected command example.</p> <p>4.4.5, 4.4.6: Removed unnecessary values from the table.</p> <p>4.5.6, 4.5.7: Changed “Switched” to “Single Cable”.</p> <p>4.5.9, 4.5.10, 4.5.11, 4.5.12: Removed unused values.</p> <p>4.5.37, 4.5.38: Corrected the command example and changed unnecessary parameters to “Reserved”.</p> <p>4.5.39, 4.5.40: Added parameters.</p> <p>5.2.6, 5.2.7: Corrected Unit No from unused to Device ID.</p> <p>6.5: Modified Input Gain Table.</p> <p>6.7: Added Attenuation Level Table.</p>
2023/06/26	4.0	<p>3: Added camera-related commands to Command List.</p> <p>4.6: Added Camera Command Details.</p> <p>4.6.1 - 4.6.7: Added camera-related commands.</p> <p>4.2.13: Added Device ID Change Request command.</p> <p>4.2.14: Added Device ID Acquisition Request command.</p> <p>4.2.15: Added Device ID Format Setting Request command.</p> <p>4.5.35: Added the value to External Control Setting Change Request.</p> <p>4.5.36: Added the value to External Control Setting Acquisition Request.</p>
2023/10/27	5.0	<p>3: Added Voice Lift, Dante Tx5, Device ID related commands to Command List.</p> <p>4.3.5, 4.3.6: Revised command format values.</p> <p>4.3.15: Added Voice Lift Setting Change Request command.</p> <p>4.3.16: Added Voice Lift Setting Acquisition Request command.</p> <p>4.3.17: Added Voice Lift Channel Setting Change Request command.</p> <p>4.3.18: Added Voice Lift Channel Setting Acquisition Request command.</p> <p>4.3.19: Added Voice Lift EQ Setting Change Request command.</p> <p>4.3.20: Added Voice Lift EQ Setting Acquisition Request command.</p> <p>4.5.37, 4.5.38: Changed Group ID to Enable.</p> <p>4.5.39, 4.5.40: Renamed Separate to Priority for Tx6.</p> <p>4.5.44: Added Dante Tx5 Setting Change Request command.</p> <p>4.5.45: Added Dante Tx5 Setting Acquisition Request command.</p>

Date	Version	Description of change
		5.2.1: Added Voice Lift Channel level meter to Level 14. Changed unused parameters to "Reserved". 6.8: Changed the format of Version correspondence table.
2024/07/09	6.0	3: Added Voice Lift Output Select Command to Command List. 4.6.1: Changed the condition for the validity of port number. 4.6.2: Corrected the command parameter example. 4.3.21: Added Voice Lift Output Select Setting Change Request command. 4.3.22: Added Voice Lift Output Select Setting Acquisition Request command. 4.5.46: Added Room Type Setting Change Request command. 4.5.47: Added Room Type Setting Acquisition Request command.
2024/10/31	7.0	4.6.1: Changed the condition for the validity of port number.
2025/04/17	8.0	4.3.12, 4.3.14, 4.3.16, 4.3.18, 4.3.20, 4.3.22: Corrected typos. 3 Command List: Corrected typos in No. 82, 83, and 84 command names. 4.5.48: Added Talker Position Information Acquisition Request command.

Table of Contents

Revision history	1
1 Preface	5
1.1 Purpose of This Document	5
1.2 Definition of Terms and Numeric Representation	5
2 Basic Specifications.....	6
2.1 Communication Interfaces	6
2.2 Command Formats	6
2.2.1 Command Common Rules	6
2.2.2 Set Command/Get Command	8
2.2.3 ACK.....	9
2.2.4 NAK.....	9
2.2.5 Answer.....	11
2.2.6 Information.....	11
2.2.7 Request.....	11
3 Command List.....	13
4 TCP Communications.....	17
4.1 Communication Control	17
4.1.1 Communication Start	18
4.1.2 Control Sequence.....	18
4.1.3 Communication Errors.....	19
4.1.4 Communication End	21
4.2 Individual Command Details	22
4.2.1 Input CH Level Change Request.....	22
4.2.2 Input CH Level Acquisition Request.....	23
4.2.3 Input CH Mute Status Change Request.....	25
4.2.4 Input CH Mute Status Acquisition Request	26
4.2.5 Output CH Level Change Request.....	28
4.2.6 Output CH Level Acquisition Request	29
4.2.7 Output CH Mute Status Change Request	31
4.2.8 Output CH Mute Status Acquisition Request	32
4.2.9 Preset Call Request.....	34
4.2.10 Preset Save Request.....	35
4.2.11 Device Mute Request	36
4.2.12 VAD Enable State Change Request.....	37
4.2.13 Device ID Change Request.....	38
4.2.14 Device ID Acquisition Request	39
4.2.15 Device ID Format Setting Request.....	41
4.3 Input Command Details	42
4.3.1 Input Gain&Level Setting Change Request	42

4.3.2	Input Gain&Level Setting Acquisition Request.....	44
4.3.3	Input Channel Setting Change Request.....	45
4.3.4	Input Channel Setting Acquisition Request	49
4.3.5	Input EQ Setting Change Request	51
4.3.6	Input EQ Setting Acquisition Request	54
4.3.7	Gain Share Setting Change Request.....	56
4.3.8	Gain Share Setting Acquisition Request	57
4.3.9	AEC Setting Change Request.....	59
4.3.10	AEC Setting Acquisition Request	61
4.3.11	AGC Setting Change Request.....	63
4.3.12	AGC Setting Acquisition Request.....	64
4.3.13	Gain Share Mode Change Request	66
4.3.14	Gain Share Mode Acquisition Request.....	67
4.3.15	Voice Lift Setting Change Request.....	67
4.3.16	Voice Lift Setting Acquisition Request	69
4.3.17	Voice Lift Channel Setting Change Request	71
4.3.18	Voice Lift Channel Setting Acquisition Request	73
4.3.19	Voice Lift EQ Setting Change Request	75
4.3.20	Voice Lift EQ Setting Acquisition Request.....	77
4.3.21	Voice Lift Output Select Setting Change Request.....	79
4.3.22	Voice Lift Output Select Setting Acquisition Request.....	80
4.4	Output Command Details.....	82
4.4.1	Output Level Setting Change Request.....	82
4.4.2	Output Level Setting Acquisition Request	83
4.4.3	Output Channel Mute Setting Change Request.....	85
4.4.4	Output Channel Mute Setting Acquisition Request	86
4.4.5	Output Channel Setting Change Request.....	88
4.4.6	Output Channel Setting Acquisition Request	90
4.5	System Command Details	92
4.5.1	Factory Default Setting Request	92
4.5.2	Permission Setting Change Request	94
4.5.3	Permission Setting Acquisition Request.....	96
4.5.4	Network Setting Change Request.....	98
4.5.5	Network Setting Acquisition Request	100
4.5.6	Dante Setting Change Request.....	103
4.5.7	Dante Setting Acquisition Request	105
4.5.8	Firmware Version Acquisition Request.....	107
4.5.9	Device Color Setting Change Request.....	107
4.5.10	Device Color Setting Acquisition Request.....	109
4.5.11	Log Setting Change Request	111
4.5.12	Log Setting Acquisition Request.....	112
4.5.13	LED Setting Change Request	114

4.5.14	LED Setting Acquisition Request.....	116
4.5.15	Preset Call Request.....	118
4.5.16	Preset Save Request.....	119
4.5.17	Preset Bank Name Change Request	120
4.5.18	Preset Bank Name Acquisition Request	121
4.5.19	Boot Up Preset Setting Change Request.....	123
4.5.20	Boot Up Preset Setting Acquisition Request	124
4.5.21	File Transfer Request	126
4.5.22	File Transfer Cancel Request	128
4.5.23	Export Request.....	129
4.5.24	Import Request	131
4.5.25	Level Meter Notification Interval Change Request.....	132
4.5.26	Level Meter Notification Interval Acquisition Request	133
4.5.27	Talker Position Notification Interval Change Request	135
4.5.28	Talker Position Notification Interval Acquisition Request	136
4.5.29	Identify Request.....	138
4.5.30	Date Setting Request	139
4.5.31	Reboot Request.....	140
4.5.32	Device ID Change Request.....	141
4.5.33	Device ID Acquisition Request	142
4.5.34	Preset Number Acquisition Request.....	142
4.5.35	External Control Setting Change Request	144
4.5.36	External Control Setting Acquisition Request.....	146
4.5.37	Device Sync Control Change Request.....	148
4.5.38	Device Sync Control Acquisition Request	149
4.5.39	Audio System Setting Change Request.....	151
4.5.40	Audio System Setting Acquisition Request	152
4.5.41	Power Save Mode Request.....	154
4.5.42	Device Mute Request	155
4.5.43	Device Mute Status Acquisition Request	156
4.5.44	Dante Tx5 Setting Change Request.....	158
4.5.45	Dante Tx5 Setting Acquisition Request	159
4.5.46	Room Type Setting Change Request.....	161
4.5.47	Room Type Setting Acquisition Request	162
4.5.48	Talker Position Information Acquisition Request	164
4.6	Camera Command Details	166
4.6.1	Camera Device Setting Change Request	166
4.6.2	Camera Device Setting Acquisition Request.....	166
4.6.3	Camera Preset Setting Change Request.....	169
4.6.4	Camera Preset Setting Acquisition Request	171
4.6.5	Camera Control Time Setting Change Request.....	172
4.6.6	Camera Control Time Setting Acquisition Request	174

4.6.7	Camera Control Pause Request	176
5	UDP Communications	177
5.1	Communication Control	177
5.1.1	Communication Start	177
5.1.2	Control Sequence	177
5.1.3	Communication Errors	177
5.1.4	Communication End	177
5.2	Command Details	178
5.2.1	Level Meter Notification	178
5.2.2	Input Gain&Level Setting Notification	181
5.2.3	Output Level Setting Notification	182
5.2.4	Output Channel Mute Setting Notification	183
5.2.5	Preset Call Notification	184
5.2.6	Talker Position Notification	185
5.2.7	Power Save Mode Notification	186
5.2.8	Device Mute Notification	187
6	Appendix	188
6.1	Fader Table	188
6.2	Frequency Table	189
6.3	Q Value Table	190
6.4	EQ Gain Table	191
6.5	Input Gain Table	192
6.6	Transfer data type	193
6.7	Attenuation Level Table	193
6.8	Version correspondence table	194

1 Preface

1.1 Purpose of This Document

This document describes the command specifications to control the ATND1061 developed in Audio-Technica.

1.2 Definition of Terms and Numeric Representation

The following table shows the definition of terms used in this document.

Term	Description
Host	A device that issues control commands. It refers to application software or a control device.
Device	A device to be controlled.
AT device	A device developed by Audio-Technica.
Message	A character string transmitted per communication in data format.
Command	A command statement to control a device. It is included in a message.
Parameter	Used in combination with a command. It is a setting value that specifies a command behavior.

The numeric representation is defined as follows:

Binary number: A value followed by b Example: 1010 0110b

Hexadecimal number: A value preceded by 0x Example: 0xA6

2 Basic Specifications

The IP control function uses TCP or UDP protocol to control the ATND1061.

2.1 Communication Interfaces

Table 2-1 Communication Interfaces

No	Item	Content	Remarks
1.	Communication system	Full duplex	
2.	Transmission speed	10Mbps / 100Mbps	
3.	Port number	Described later	
4.	Maximum data length	287 bytes (including carriage return codes)	32 bytes for Ethernet communication header, 255 bytes for control command
5.	Compatible connector	Device: RJ45 connector (compatible with 10/100 Mbps) Cable: CAT5e or higher	

2.2 Command Formats

Transmitted commands are categorized as follows:

Table 2-2 Communication Interfaces

No	Command	Content	Remarks
1.	Set Command	Action command	Change the ATND1061 settings.
2.	Get Command	Action command	Obtain the ATND1061 settings and status.
3.	ACK	Acknowledge	Responds to a Set Command.
4.	NAK	Negative acknowledge	Responds to a Set/Get Command.
5.	Answer	Setting change notification	Responds to a Get Command.
6.	Information	Status change notification	Reports the ATND1061 settings and status change.
7.	Request	Action request	Requests an action to the host.

2.2.1 Command Common Rules

(1) Use a single-byte space (␣: 0x20) as a delimiter.

- (2) In general, use ASCII codes for commands and UTF-8 for the parameters of specific commands (Example: Naming a device, etc.).
- (3) Add CR (0x0d) to the end of each command.

Example:

factory_settings _S_0000_00_NC_0_↓

factory_settings _ACK_↓

factory_settings _NAK_01_↓

g_deviceid _O_0000_00_NC_↓

MD open_channel_notice_0000_00_NC_0,0,0,0,0,0_↓

- _ : Indicates a space.
- ↓ : Indicates CR (0x0d).
- █ : Indicates a command parameter.

2.2.3ACK

The acknowledge command format is shown below.

Table 2-4 Acknowledge Command Format

No	Item	Content	Size	Remarks
1.	Command	Command string	0 bytes or more	See 3. Command List.
2.	ACK	ACK	3byte	ACK (fixed)
3.	End Character	Message end character	1byte	CR (0x0D)

2.2.4NAK

The negative acknowledge command format is shown below.

Table 2-5 Negative Acknowledge Command Format

No	Item	Content	Size	Remarks
1.	Command	Command string	0 bytes or more	See 3. Command List.
2.	NAK	NAK	3byte	NAK (fixed)
3.	Error Code	Error code	2byte	See <u>Table 2-6</u> .
4.	End Character	Message end character	1byte	CR (0x0D)

2.2.4.1 Error Codes

The error codes are shown below.

Table 2-6 Error Codes

Error code	Error description	Remarks
01	Syntax error	<ul style="list-style-type: none">• A required element is not found.• The character string of a required element is incorrect.• The character string length for each element is outside the specified range.• The message string length including carriage return codes is greater than the upper limit.
02	Invalid command	<ul style="list-style-type: none">• The command is not found. (A non-existing command was specified. A command that cannot be used for the device was specified.)
03	Splitting transmission error	<ul style="list-style-type: none">• "CM" or "CE" was specified when "CS" of Continue Select had not been received.
04	Parameter error	<ul style="list-style-type: none">• The parameter is outside the specified range.• Changing a parameter that cannot be changed was attempted.
05	Transmission timeout	Not used
90	Busy	Unable to process due to a busy state
92	Busy (Save mode)	Unable to process due to p-Fail (power shutdown) occurrence
93	Busy(Extension)	Not used
99	Other errors	Errors other than the above

2.2.5 Answer

The command format of the setting status response is shown below.

Table 2-7 Setting Status Return Command Format

No	Item	Content	size	Remarks
1.	Command	Command string	0 bytes or more	See 3. Command List.
2.	Model ID	Not used	4byte	0000 (fixed)
3.	Unit No	Device ID	2byte	00 to FF
4.	Continue Select	Message split method	2byte	NC: No divided message CS: Head of divided message CM: Divided message CE: End of divided message
5.	Parameter	Command parameter	0 bytes or more	See Chapters 4 and 4.6.
6.	End Character	Message end character	1byte	CR (0x0D)

2.2.6 Information

The command format of the status change notification is shown below.

Table 2-8 Status Change Notification Command Format

No	Item	Content	size	Remarks
1.	Modify	MD	2byte	MD (fixed)
2.	Command	Command string	5byte	See 3. Command List.
3.	Model ID	Not used	4byte	0000 (fixed)
4.	Unit No	Device ID	2byte	00 to FF
5.	Continue Select	Message split method	2byte	NC: No divided message CS: Head of divided message CM: Divided message CE: End of divided message
6.	Parameter	Command parameter	0 bytes or more	See Chapter 4.6.
7.	End Character	Message end character	1byte	CR (0x0D)

2.2.7 Request

The action request command format is shown below.

Table 2-9 Action Request Command Format

No	Item	Content	size	Remarks
1	Request	RQ	2byte	RQ (fixed)
2	Command	Command string	5byte	See 3. Command List.
3	Model ID	Not used	4byte	0000 (fixed)
4	Unit No	Not used	2byte	00 (fixed)
5	Continue Select	Message split method	2byte	NC: No divided message CS: Head of divided message CM: Divided message CE: End of divided message
6	Parameter	Command parameter	0 bytes or more	See Chapter 4.
7	End Character	Message end character	1byte	CR (0x0D)

3 Command List

Table 3-1 Command List

No	Category	Command	Command Name	Remarks	Type			Ref.
					set	get	info	
1	Individual command	SICL	Input CH Level Change Request		○			22
2		GICL	Input CH Level Acquisition Request			○		23
3		SICM	Input CH Mute Status Change Request		○			25
4		GICM	Input CH Mute Status Acquisition Request			○		26
5		SOCL	Output CH Level Change Request		○			28
6		GOCL	Output CH Level Acquisition Request			○		29
7		SOCM	Output CH Mute Status Change Request		○			31
8		GOCM	Output CH Mute Status Acquisition Request			○		32
9		CALLP	Preset Call Request		○			34
10		REGIP	Preset Save Request		○			35
11		MUTE	Device Mute Request		○			36
12		SVAD	VAD Enable State Change Request		○			37
13		SDID	Device ID Change Request		○			38
14		GDID	Device ID Acquisition Request			○		39
15		SFID	Device ID Format Setting Request		○			41
16	Input	s_input_gain_level	Input Gain&Level Setting Change Request		○			42
17		g_input_gain_level	Input Gain&Level Setting Acquisition Request			○		44
18		input_gain_level_meter_notice	Input Gain&Level Setting Notification				○	181
19		s_input_channel_settings	Input Channel Setting Change Request		○			45
20		g_input_channel_settings	Input Channel Setting Acquisition Request			○		49
21		s_input_eq	Input EQ Setting Change Request		○			51
22		g_input_eq	Input EQ Setting Acquisition Request			○		54
23		s_aec_general	AEC Setting Change Request		○			59
24		g_aec_general	AEC Setting Acquisition Request			○		61
25		s_smart_mix	Gain Share Setting Change Request		○			56
26		g_smart_mix	Gain Share Setting Acquisition Request			○		57
27		s_agc	AGC Setting Change Request		○			63
28		g_agc	AGC Setting Acquisition Request			○		64

No	Category	Command	Command Name	Remarks	Type			Ref.
					set	get	info	
29		s_gainshare_mode	Gain Share Mode Change Request		○			66
30		g_gainshare_mode	Gain Share Mode Acquisition Request			○		67
31		s_voicelift	Voice Lift Setting Change Request		○			67
32		g_voicelift	Voice Lift Setting Acquisition Request			○		69
33		s_voicelift_channel_settings	Voice Lift Channel Setting Change Request		○			71
34		g_voicelift_channel_settings	Voice Lift Channel Setting Acquisition Request			○		73
35		s_voicelift_eq	Voice Lift EQ Setting Change Request		○			75
36		g_voicelift_eq	Voice Lift EQ Setting Acquisition Request			○		77
37		s_voicelift_outputselect	Voice Lift Output Select Setting Change Request		○			79
38		g_voicelift_outputselect	Voice Lift Output Select Setting Acquisition Request			○		80
39	Output	s_output_level	Output Level Setting Change Request		○			82
40		g_output_level	Output Level Setting Acquisition Request			○		83
41		output_level_notice	Output Level Setting Notification				○	182
42		s_output_mute	Output Channel Mute Setting Change Request		○			85
43		g_output_mute	Output Channel Mute Setting Acquisition Request			○		86
44		output_mute_notice	Output Channel Mute Setting Notification				○	183
45		s_output_channel_settings	Output Channel Setting Change Request		○			88
46		g_output_channel_settings	Output Channel Setting Acquisition Request			○		90
47	System	factory_settings	Factory Default Setting Request		○			92
48		s_deviceid	Device ID Change Request		○			141
49		g_deviceid	Device ID Acquisition Request			○		142
50		s_permission	Permission Setting Change Request		○			94
51		g_permission	Permission Setting Acquisition Request			○		96
52		s_network	Network Setting Change Request		○			98
53		g_network	Network Setting Acquisition Request			○		100
54		s_network_dante	Dante Setting Change Request		○			103
55		g_network_dante	Dante Setting Acquisition Request			○		105
56		g_firmware_version	Firmware Version Acquisition Request			○		107
57		s_header_color	Device Color Setting Change Request		○			107

No	Category	Command	Command Name	Remarks	Type			Ref.
					set	get	info	
58		g_header_color	Device Color Setting Acquisition Request			○		109
59		s_log	Log Setting Change Request		○			111
60		g_log	Log Setting Acquisition Request			○		112
61		s_remotecontrol	External Control Setting Change Request		○			144
62		g_remotecontrol	External Control Setting Acquisition Request			○		146
63		s_syncontrol	Device Sync Control Change Request		○			148
64		g_syncontrol	Device Sync Control Acquisition Request			○		149
65		s_audio_system	Audio System Setting Change Request		○			151
66		g_audio_system	Audio System Setting Acquisition Request			○		152
67		call_preset	Preset Call Request		○			118
68		save_preset	Preset Save Request		○			119
69		s_name_bank	Preset Bank Name Change Request		○			120
70		g_name_bank	Preset Bank Name Acquisition Request			○		121
71		s_bootup_preset	Boot Up Preset Setting Change Request		○			123
72		g_bootup_preset	Boot Up Preset Setting Acquisition Request			○		124
73		g_preset_number	Preset Number Acquisition Request			○		142
74		recall_preset_notice	Preset Call Notification				○	184
75		file_transfer	File Transfer Request		○			126
76		file_transfer_cancel	File Transfer Cancel Request		○			128
77		export	Export Request			○		129
78		import	Import Request		○			131
79		s_level_meter_interval	Level Meter Notification Interval Change Request		○			132
80		g_level_meter_interval	Level Meter Notification Interval Acquisition Request			○		133
81		level_meter_notice	Level Meter Notification				○	178
82		s_camera_control_interval	Talker Position Notification Interval Change Request		○			135
83		g_camera_control_interval	Talker Position Notification Interval Acquisition Request			○		136
84		g_camera_control_notice	Talker Position Information Acquisition Request			○		164
85		camera_control_notice	Talker Position Notification				○	185
86		identify	Identify Request		○			138

No	Category	Command	Command Name	Remarks	Type			Ref.	
					set	get	info		
87		s_date	Date Setting Request		○			139	
88		reboot	Reboot Request		○			140	
89		s_powersave	Power Save Mode Request		○			154	
90		powersave_notice	Power Save Mode Notification				○	186	
91		s_mute	Device Mute Request		○			155	
92		g_mute	Device Mute Status Acquisition Request			○		156	
93		mute_notice	Device Mute Notification				○	187	
94		s_dante_tx5	Dante Tx5 Setting Change Request		○			158	
95		g_dante_tx5	Dante Tx5 Setting Acquisition Request			○		159	
96		s_roomtype	Room Type Setting Change Request		○			161	
97		g_roomtype	Room Type Setting Acquisition Request			○		162	
98		Camera	s_camera_device	Camera Device Setting Change Request		○			166
99			g_camera_device	Camera Device Setting Acquisition Request			○		166
100			s_camera_preset	Camera Preset Setting Change Request		○			169
101	g_camera_preset		Camera Preset Setting Acquisition Request			○		171	
102	s_camera_control		Camera Control Time Setting Change Request		○			172	
103	g_camera_control		Camera Control Time Setting Acquisition Request			○		174	
104	s_camera_stop		Camera Control Pause Request		○			176	

4 TCP Communications

To control the ATND1061 from the host, TCP protocol is used for communications.

4.1 Communication Control

The following figure shows the communication control flow of IP control.

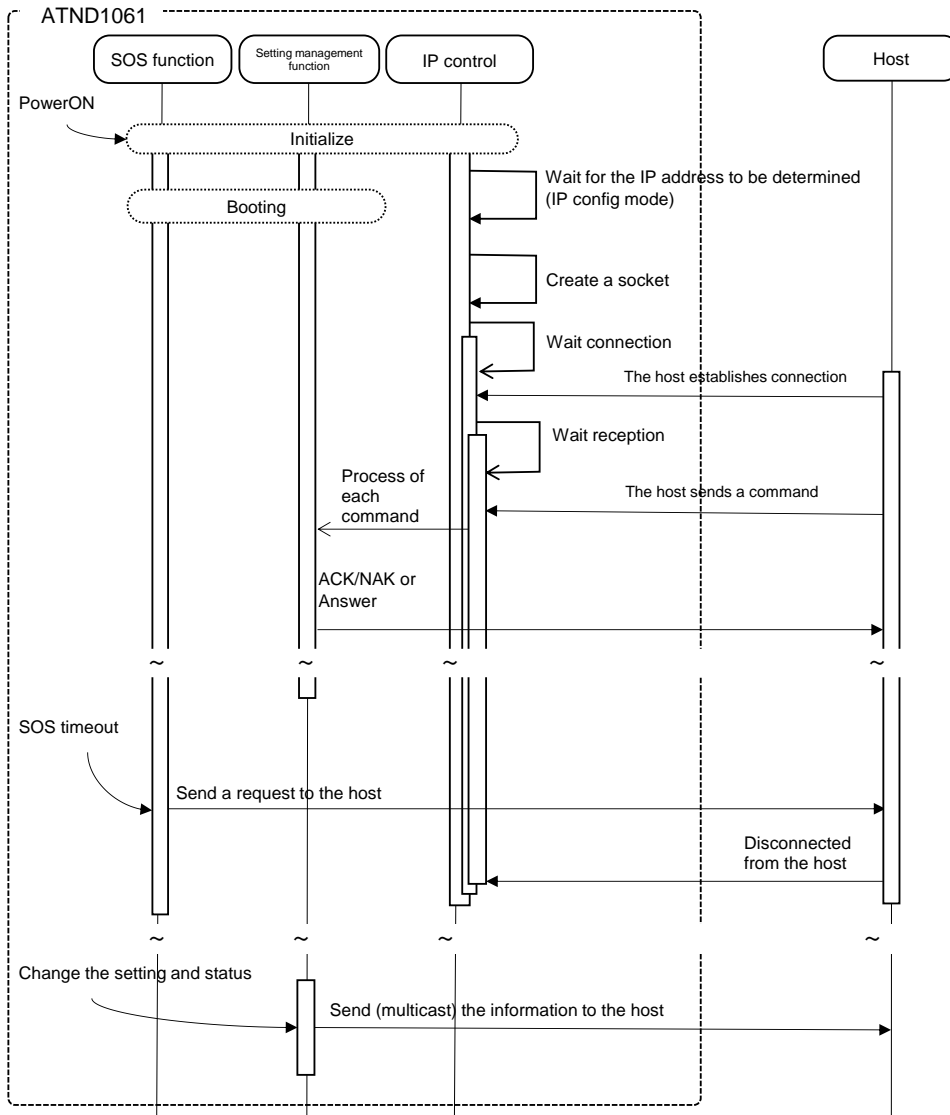

Figure 4-1 Communication Control Flow

- After the system is booted, the status changes from initializing to connection waiting.
- When the host establishes connection with the system, the status changes from connection waiting to reception waiting.
- Received commands are processed by internal processing tasks, and the results (ACK/NAK) are sent.
Since commands are asynchronously processed, reception is possible even during processing (The next command can be sent without waiting for ACK/NAK and Answer). However, some commands return NAK (90: BUSY).
- When the system is disconnected from the host, the status changes from reception waiting to connection waiting.

4.1.1 Communication Start

The host establishes connections with the ATND1061.

Simultaneous connection is limited to five devices. If the number exceeds the upper limit, the extra connection fails.

Table 4-1 Communication Control Parameters

No	Name	Default Setting	Remarks
1.	IPAddress	Auto	
2.	Port No	17300	

4.1.2 Control Sequence

4.1.2.1 Set Command

Responding to a Set Command, the ATND1061 sends ACK/NAK to the sender.

<Example> The sequence of factory default setting is shown below.

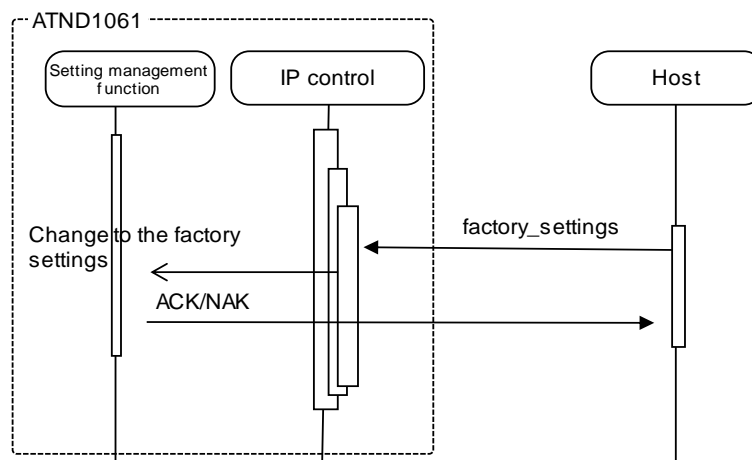

Figure 4-2 Set Command Processing Sequence

If an error occurs in a Set Command, such as a syntax error or incorrect parameter, an NAK command is sent to the sender.

4.1.2.2 Get Command

Responding to a Get Command, the ATND1061 sends Answer to the sender.

<Example> The sequence of Output Level Setting Acquisition Request is shown below.

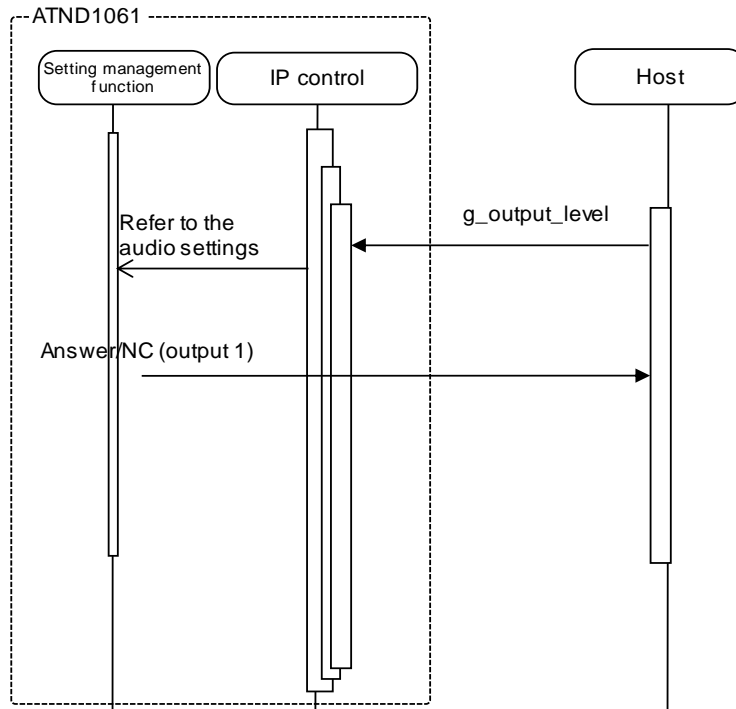

Figure 4-3 Get Command Processing Sequence

If an error occurs in a Get Command, such as a syntax error or incorrect parameter, an NAK command is sent to the sender.

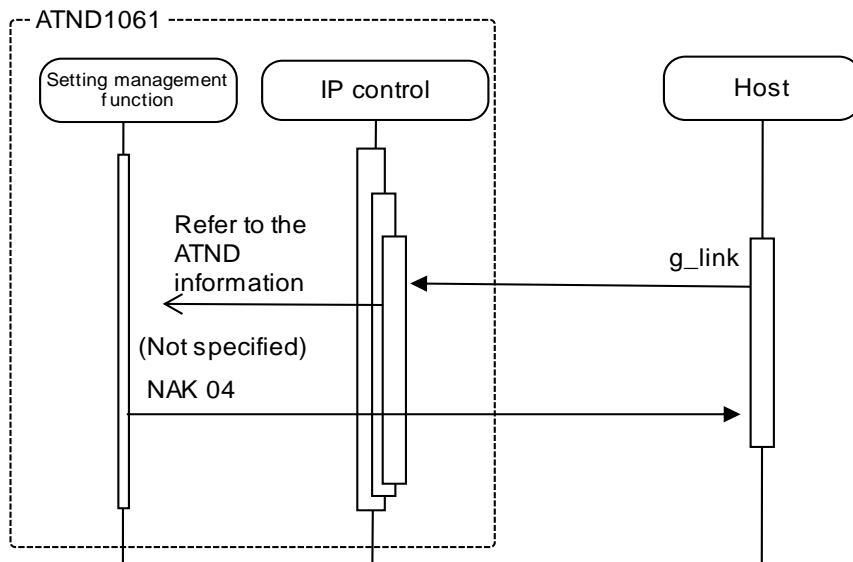

Figure 4-4 Get Command Processing Sequence (NAK)

4.1.3 Communication Errors

4.1.3.1 Transmission error

The following figure shows the sequence when an ACK/NAK transmission error occurs.

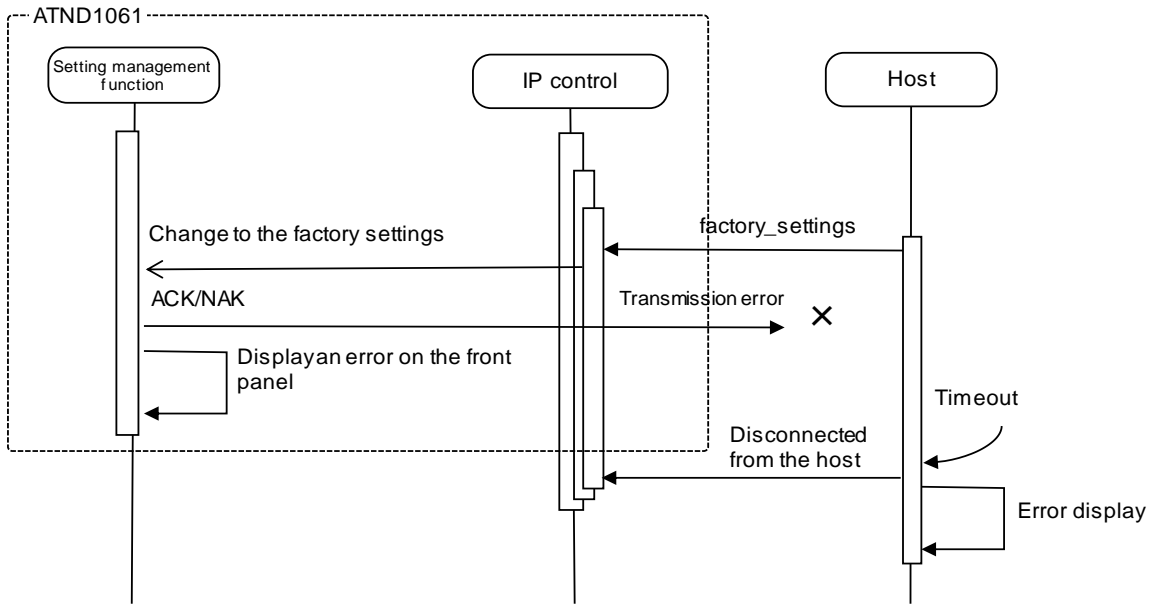

Figure 4-5 Sequence for Transmission Errors

4.1.3.2 Receive error

The following figure shows the sequence when a command receive error occurs.

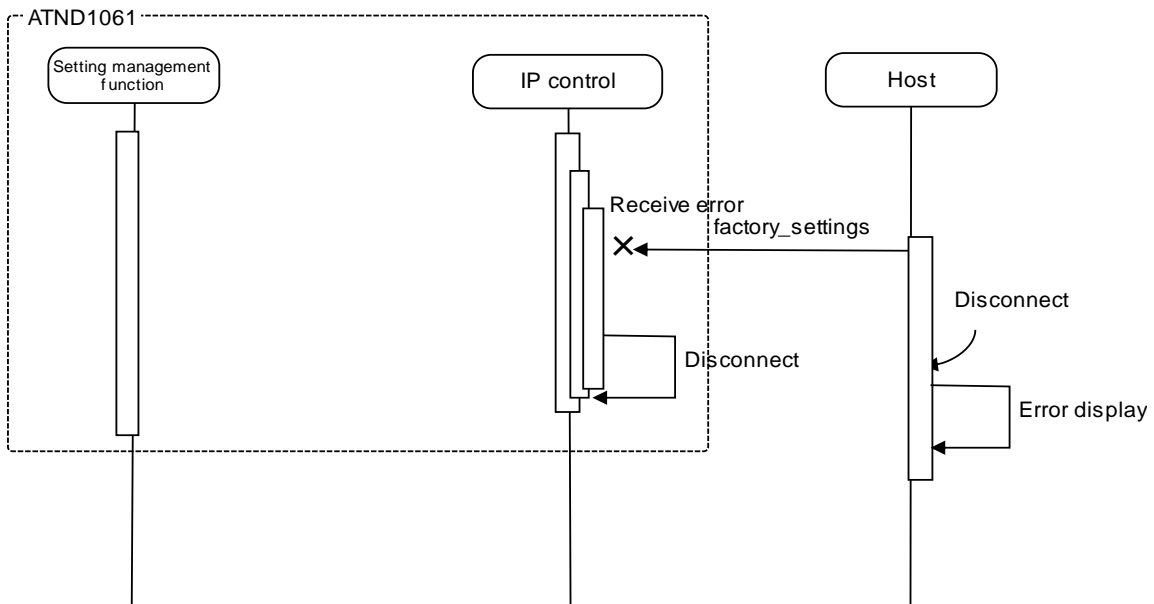

Figure 4-6 Sequence for Receive Errors

4.1.3.3 Message Split Receive Timeouts

The following figure shows the sequence when a message split receive timeout occurs.

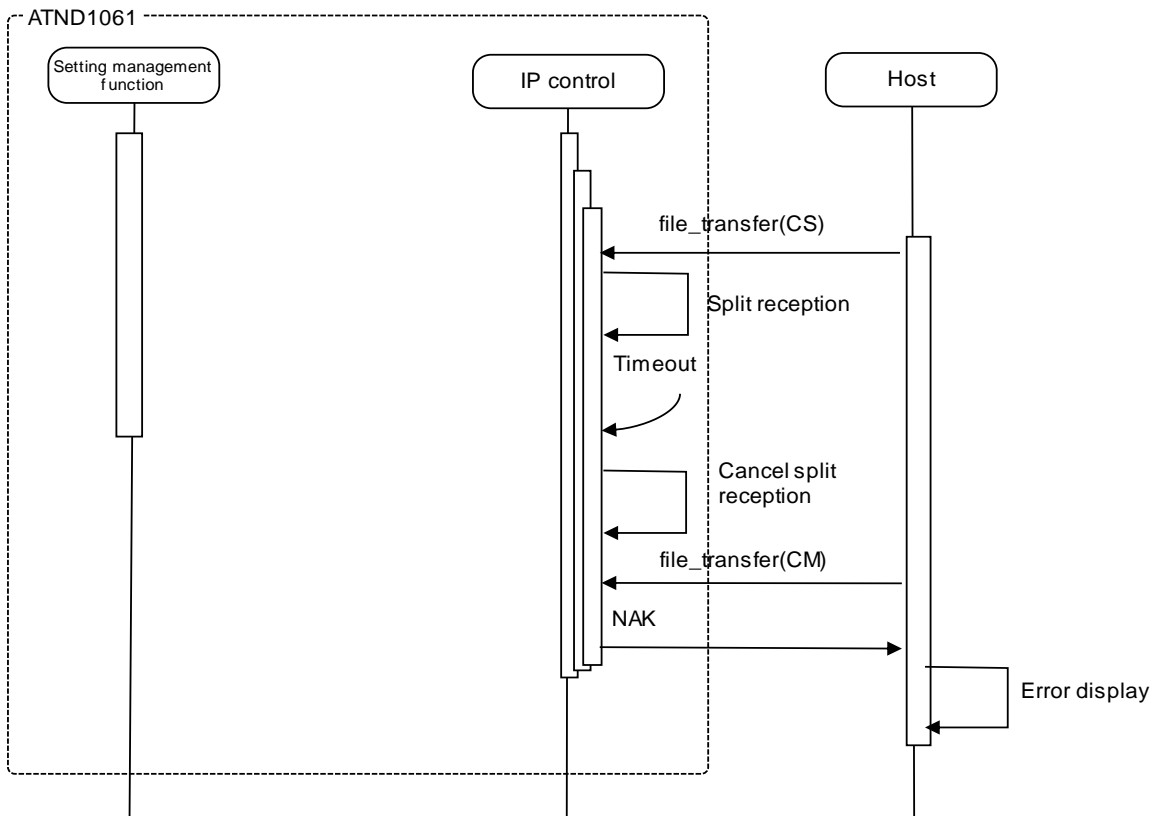

Figure 4-7 Sequence for Message Split Receive Timeouts

4.1.4 Communication End

The host can be disconnected at any timing when communications end.

When it is disconnected, the ATND1061 clears the corresponding connection state (Example: File transferring) and enters the connection wait state again. This occurs even if a cable is disconnected.

To communicate again, the host needs to establish connection.

4.2 Individual Command Details

4.2.1 Input CH Level Change Request

After receiving the Input CH Level Change Request, the ATND1061 sends the processing results to the host via ACK or NAK.

(1) Set Command

The command format of the Input CH Level Change Request from the host is shown below.

SICL_S_0000_00_NC_6,511_↓

Table 4-2 Command Format

No	item	Description	type	value	value description	remarks
1	Command	Command string	string	SICL		
2	HandShake Select	Sequence execution method	string	S		
3	Model ID	Not used	string	0000	Not used	
4	Unit No	Not used	string	00	Not used	
5	Continue Select	Message split method	string	NC	No split	
6	Parameter	Parameter				
	Input Channel Select	Input channel selection	string	0 to 5 6	Beam Channel 1 to 6 Analog Input	
	Level	Level	string	0 to 511	-∞, -120 to +10 dB	See 6.1 Fader Table.
7	End Character	Message end character	binary	0x0d	CR	

(2) ACK/NAK

See Factory Default Setting Request (2).

4.2.2 Input CH Level Acquisition Request

After receiving the Input CH Level Acquisition Request, the ATND1061 sends the input CH level to the host via Answer.

(1) Get Command

The command format of the Input CH Level Acquisition Request from the host is shown below.

GICL_O_0000_00_NC_6_↵

Table 4-3 Command Format

No	item	Description	type	value	value description	remarks
1	Command	Command string	string	GICL		
2	HandShake Select	Sequence execution method	string	O		
3	Model ID	Not used	string	0000	Not used	
4	Unit No	Not used	string	00	Not used	
5	Continue Select	Message split method	string	NC	No split	
6	Parameter Input Channel Select	Parameter Input channel selection	string	0 to 5	Beam Channel 1 to 6	
				6	Analog Input	
7	End Character	Message end character	binary	0x0d	CR	

(2) Answer

The Answer command format from the ATND1061 is shown below.

GICL_0000_00_NC_6,511_↵

Table 4-4 Answer Command Format

No	item	Description	type	value	value description	remarks
1	Command	Command string	string	GICL		
2	Model ID	Not used	string	0000	Not used	
3	Unit No	Device ID	string	00 to FF	Device ID	
4	Continue Select	Message split method	string	NC	No split	
5	Parameter	Parameter				
	Input Channel Select	Input channel selection	string	0 to 5	Beam Channel 1 to 6	
				6	Analog Input	
Level	Level	string	0 to 511	-∞, -120 to +10 dB	See 6.1 Fader Table.	
6	End Character	Message end character	binary	0x0d	CR	

4.2.3 Input CH Mute Status Change Request

After receiving the Input CH Mute Status Change Request, the ATND1061 sends the processing results to the host via ACK or NAK.

(1) Set Command

The command format of the Input CH Mute Status Change Request from the host is shown below.

SICM_S_0000_00_NC_6,1_↵

Table 4-5 Command Format

No	item	Description	type	value	value description	remarks
1	Command	Command string	string	SICM		
2	HandShake Select	Sequence execution method	string	S		
3	Model ID	Not used	string	0000	Not used	
4	Unit No	Not used	string	00	Not used	
5	Continue Select	Message split method	string	NC	No split	
6	Parameter	Parameter				
	Input Channel Select	Input channel selection	string	0 to 5	Beam Channel 1 to 6	
				6	Analog Input	
	Mute	Mute status	string	0	Not muted	
1				Muted		
7	End Character	Message end character	binary	0x0d	CR	

(2) ACK/NAK

See Factory Default Setting Request (2).

4.2.4 Input CH Mute Status Acquisition Request

After receiving the Input CH Mute Status Acquisition Request, the ATND1061 sends the input CH mute status to the host via Answer.

(1) Get Command

The command format of the Input CH Mute Status Acquisition Request from the host is shown below.

GICM_O_0000_00_NC_6_↵

Table 4-6 Command Format

No	item	Description	type	value	value description	remarks
1	Command	Command string	string	GICM		
2	HandShake Select	Sequence execution method	string	O		
3	Model ID	Not used	string	0000	Not used	
4	Unit No	Not used	string	00	Not used	
5	Continue Select	Message split method	string	NC	No split	
6	Parameter Input Channel Select	Parameter Input channel selection	string	0 to 5	Beam Channel 1 to 6	
				6	Analog Input	
7	End Character	Message end character	binary	0x0d	CR	

(2) Answer

The Answer command format from the ATND1061 is shown below.

GICM_0000_00_NC_6,1_↵

Table 4-7 Answer Command Format

No	item	Description	type	value	value description	remarks			
1	Command	Command string	string	GICM					
2	Model ID	Not used	string	0000	Not used				
3	Unit No	Device ID	string	00 to FF	Device ID				
4	Continue Select	Message split method	string	NC	No split				
5	Parameter	Parameter							
				Input Channel Select	Input channel selection	string	0 to 5	Beam Channel 1 to 6	
							6	Analog Input	
				Mute	Mute status	string	0	Not muted	
1	Muted								
6	End Character	Message end character	binary	0x0d	CR				

4.2.5 Output CH Level Change Request

After receiving the Output CH Level Change Request, the ATND1061 sends the processing results to the host via ACK or NAK.

(1) Set Command

The command format of the Output CH Level Change Request from the host is shown below.

SOCL_S_0000_00_NC_0,511_↵

Table 4-8 Command Format

No	item	Description	type	value	value description	remarks
1	Command	Command string	string	SOCL		
2	HandShake Select	Sequence execution method	string	S		
3	Model ID	Not used	string	0000	Not used	
4	Unit No	Not used	string	00	Not used	
5	Continue Select	Message split method	string	NC	No split	
6	Parameter	Parameter				
	Output Channel Select	Output channel selection	string	0	Analog Out	
				1	Auto Mix	
Level	Level	string	0 to 511	-∞, -120 to +10 dB	See 6.1 Fader Table.	
7	End Character	Message end character	binary	0x0d	CR	

(2) ACK/NAK

See Factory Default Setting Request (2).

4.2.6 Output CH Level Acquisition Request

After receiving the Output CH Level Acquisition Request, the ATND1061 sends output CH level to the host via Answer.

(1) Get Command

The command format of the Output CH Level Acquisition Request from the host is shown below.

GOCL_O_0000_00_NC_0_↓

Table 4-9 Command Format

No	item	Description	type	value	value description	remarks
1	Command	Command string	string	GOCL		
2	HandShake Select	Sequence execution method	string	O		
3	Model ID	Not used	string	0000	Not used	
4	Unit No	Not used	string	00	Not used	
5	Continue Select	Message split method	string	NC	No split	
6	Parameter Output Channel Select	Parameter Output channel selection	string	0	Analog Out	
				1	Auto Mix	
7	End Character	Message end character	binary	0x0d	CR	

(2) Answer

The Answer command format from the ATND1061 is shown below.

GOCL_0000_00_NC_0,511_↵

Table 4-10 Answer Command Format

No	item	Description	type	value	value description	remarks
1	Command	Command string	string	GOCL		
2	Model ID	Not used	string	0000	Not used	
3	Unit No	Device ID	string	00 to FF	Device ID	
4	Continue Select	Message split method	string	NC	No split	
5	Parameter	Parameter				
	Output Channel Select	Output channel selection	string	0	Analog Out	
				1	Auto Mix	
Level	Level	string	0 to 511	-∞, -120 to +10 dB	See 6.1 Fader Table.	
6	End Character	Message end character	binary	0x0d	CR	

4.2.7 Output CH Mute Status Change Request

After receiving the Output CH Mute Status Change Request, the ATND1061 sends the processing results to the host via ACK or NAK.

(1) Set Command

The command format of the Input CH Mute Status Change Request from the host is shown below.

SOCM_S_0000_00_NC_0,1_↵

Table 4-11 Command Format

No	item	Description	type	value	value description	remarks		
1	Command	Command string	string	SOCM				
2	HandShake Select	Sequence execution method	string	S				
3	Model ID	Not used	string	0000	Not used			
4	Unit No	Not used	string	00	Not used			
5	Continue Select	Message split method	string	NC	No split			
6	Parameter	Parameter						
			Output Channel Select	Output channel selection	string	0	Analog Out	
						1	Auto Mix	
			Mute	Mute status	string	0	Not muted	
1	Muted							
7	End Character	Message end character	binary	0x0d	CR			

(2) ACK/NAK

See Factory Default Setting Request (2).

4.2.8 Output CH Mute Status Acquisition Request

After receiving the Output CH Mute Status Acquisition Request, the ATND1061 sends output CH mute status to the host via Answer.

(1) Get Command

The command format of the Output CH Mute Status Acquisition Request from the host is shown below.

GOCM_O_0000_00_NC_0_↵

Table 4-12 Command Format

No	item	Description	type	value	value description	remarks
1	Command	Command string	string	GOCM		
2	HandShake Select	Sequence execution method	string	O		
3	Model ID	Not used	string	0000	Not used	
4	Unit No	Not used	string	00	Not used	
5	Continue Select	Message split method	string	NC	No split	
6	Parameter Output Channel Select	Parameter Output channel selection	string	0	Analog Out	
				1	Auto Mix	
7	End Character	Message end character	binary	0x0d	CR	

(2) Answer

The Answer command format from the ATND1061 is shown below.

GOCM_0000_00_NC_0,1_↵

Table 4-13 Answer Command Format

No	item	Description	type	value	value description	remarks			
1	Command	Command string	string	GOCM					
2	Model ID	Not used	string	0000	Not used				
3	Unit No	Device ID	string	00 to FF	Device ID				
4	Continue Select	Message split method	string	NC	No split				
5	Parameter	Parameter							
				Output Channel Select	Output channel selection	string	0	Analog Out	
							1	Auto Mix	
				Mute	Mute status	string	0	Not muted	
1	Muted								
6	End Character	Message end character	binary	0x0d	CR				

4.2.9 Preset Call Request

After receiving the Preset Call Request, the ATND1061 sends the processing results to the host via ACK or NAK.

(1) Set Command

The command format of the Preset Call Request from the host is shown below.

```
CALLP_S_0000_00_NC_16_↵
```

Table 4-14 Command Format

No	item	Description	type	value	value description	remarks
1	Command	Command string	string	CALLP		
2	HandShake Select	Sequence execution method	string	S		
3	Model ID	Not used	string	0000	Not used	
4	Unit No	Not used	string	00	Not used	
5	Continue Select	Message split method	string	NC	No split	
6	Parameter	Parameter				
	Bank Number	Bank number	string	1 to 16	Bank 1 to 16	
7	End Character	Message end character	binary	0x0d	CR	

(2) ACK/NAK

See Factory Default Setting Request (2).

4.2.10 Preset Save Request

After receiving the Preset Save Request, the ATND1061 sends the processing results to the host via ACK or NAK.

(1) Set Command

The command format of the Preset Save Request from the host is shown below.

```
REGIP_S_0000_00_NC_16_↵
```

Table 4-15 Command Format

No	item	Description	type	value	value description	remarks
1	Command	Command string	string	REGIP		
2	HandShake Select	Sequence execution method	string	S		
3	Model ID	Not used	string	0000	Not used	
4	Unit No	Not used	string	00	Not used	
5	Continue Select	Message split method	string	NC	No split	
6	Parameter	Parameter				
	Bank Number	Bank number	string	1 to 16	Bank 1 to 16	
7	End Character	Message end character	binary	0x0d	CR	

(2) ACK/NAK

See Factory Default Setting Request (2).

4.2.11 Device Mute Request

After receiving the Device Mute Request, the ATND1061 sends the processing results to the host via ACK or NAK.

(1) Set Command

The command format of the Device Mute Request from the host is shown below.

MUTE_S_0000_00_NC_1_↵

Table 4-16 Command Format

No	item	Description	type	value	value description	remarks
1	Command	Command string	string	MUTE		
2	HandShake Select	Sequence execution method	string	S		
3	Model ID	Not used	string	0000	Not used	
4	Unit No	Not used	string	00	Not used	
5	Continue Select	Message split method	string	NC	No split	
6	Parameter	Parameter				
	Mute	Mute status	string	0	Not muted	
				1	Muted	
7	End Character	Message end character	binary	0x0d	CR	

(2) ACK/NAK

See Factory Default Setting Request (2).

4.2.12 VAD Enable State Change Request

After receiving the VAD Enable State Change Request, the ATND1061 sends the processing results to the host via ACK or NAK.

(1) Set Command

The command format of the VAD Enable State Change Request from the host is shown below.

```
SVAD_S_0000_00_NC_1_↵
```

Table 4-17 Command Format

No	item	Description	type	value	value description	remarks
1	Command	Command string	string	SVAD		
2	HandShake Select	Sequence execution method	string	S		
3	Model ID	Not used	string	0000	Not used	
4	Unit No	Not used	string	00	Not used	
5	Continue Select	Message split method	string	NC	No split	
6	Parameter	Parameter				
				VAD Enabled	VAD enabled	string
				1	VAD enabled	
7	End Character	Message end character	binary	0x0d	CR	

(2) ACK/NAK

See Factory Default Setting Request (2).

4.2.13 Device ID Change Request

After receiving the Device ID Change Request, the ATND1061 sends the processing results to the host via ACK or NAK.

(1) Set Command

The command format of the Device ID Change Request from the host is shown below.

SDID_S_0000_00_NC_03E7_↵

Table 4-18 Command Format

No	item	Description	type	value	value description	remarks
1	Command	Command string	string	SDID		
2	HandShake Select	Sequence execution method	string	S		
3	Model ID	Not used	string	0000	Not used	
4	Unit No	Not used	string	00	Not used	
5	Continue Select	Message split method	string	NC	No split	
6	Parameter	Parameter				
	Device ID	Device ID	string	0000 to 03E7 or 0 to 999	Device ID	Set by SFID command
7	End Character	Message end character	binary	0x0d	CR	

(2) ACK/NAK

See Factory Default Setting Request (2).

4.2.14 Device ID Acquisition Request

After receiving the Device ID Acquisition Request, the ATND1061 sends the device ID settings to the host via answer.

(1) Get Command

The command of the Device ID Acquisition Request from the host is shown below.

GDID_O_0000_00_NC_↵

Table 4-19 Command Format

No	item	Description	type	value	value description	remarks
1	Command	Command string	string	GDID		
2	HandShake Select	Sequence execution method	string	O		
3	Model ID	Not used	string	0000	Not used	
4	Unit No	Not used	string	00	Not used	
5	Continue Select	Message split method	string	NC	No split	
6	Parameter	Parameter	-	-	No parameter	
7	End Character	Message end character	binary	0x0d	CR	

(2) Answer

The Answer command format from the ATND1061 is shown below.

GDID_0000_00_NC_03E7_↓

Table 4-20 Answer Command Format

No	item	Description	type	value	value description	remarks
1	Command	Command string	string	g_deviceid		
2	Model ID	Not used	string	0000	Not used	
3	Unit No	Device ID	string	00 to FF	Device ID	
4	Continue Select	Message split method	string	NC	No split	
5	Parameter	Parameter				
	Device ID	Device ID	string	0000 to 03E7 or 0 to 999	Device ID	Set by SFID command
6	End Character	Message end character	binary	0x0d	CR	

4.2.15 Device ID Format Setting Request

After receiving the Device ID Format Setting Request, the ATND1061 sends the processing results to the host via ACK or NAK.

(1) Set Command

The command format of the Device ID Format Setting Request from the host is shown below.

SFID_S_0000_00_NC_1_↵

Table 4-21 Command Format

No	item	Description	type	value	value description	remarks
1	Command	Command string	string	SFID		
2	HandShake Select	Sequence execution method	string	S		
3	Model ID	Not used	string	0000	Not used	
4	Unit No	Not used	string	00	Not used	
5	Continue Select	Message split method	string	NC	No split	
6	Parameter	Parameter				
	Format	Device ID format	string	0	Hexadecimal number	
				1	Decimal number	
7	End Character	Message end character	binary	0x0d	CR	

(2) ACK/NAK

See Factory Default Setting Request (2).

4.3 Input Command Details

4.3.1 Input Gain&Level Setting Change Request

After receiving the Input Gain&Level Setting Change Request, the ATND1061 sends the processing results to the host via ACK or NAK.

(1) Set Command

The command format of the Input Gain&Level Setting Change Request from the host is shown below.

s_input_gain_level_S_0000_00_NC_6,30,,511,,,1,,,↵

Table 4-22 Command Format

No	item	Description	type	value	value description	remarks	
1	Command	Command string	string	s_input_gain_level			
2	HandShake Select	Sequence execution method	string	S			
3	Model ID	Not used	string	0000	Not used		
4	Unit No	Not used	string	00	Not used		
5	Continue Select	Message split method	string	NC	No split		
6	Parameter	Parameter					
	Input Channel Select	Input channel selection	string	0 to 5	Beam Channel 1 to 6		
				6	Analog Input		
	gain						
	Mic	Mic gain	string	0 to 30	+0dB to +30dB	See 6.5 Input Gain Table. Disabled for analog input.	
	Reserved	Reserved	string				
	Level	Level	string	0 to 511	-120dB to +10dB	See 6.1 Fader Table.	
	Reserved						
	Reserved	Reserved	string				
	Reserved	Reserved	string				
	Mute	Mute status	string	0	Not muted		
				1	Muted		
	Reserved	Reserved	string				
	Reserved						
Reserved	Reserved	string					

No	item	Description	type	value	value description	remarks
	Reserved	Reserved	string			
7	End Character	Message end character	binary	0x0d	CR	

(2) ACK/NAK

See Factory Default Setting Request (2).

4.3.2 Input Gain&Level Setting Acquisition Request

After receiving the Input Gain&Level Setting Acquisition Request, the ATND1061 sends the input settings to the host via Answer.

(1) Get Command

The command format of the Input Gain&Level Setting Acquisition Request from the host is shown below.

g_input_gain_level_O_0000_00_NC_6_↓

Table 4-23 Command Format

No	item	Description	type	value	value description	remarks
1	Command	Command string	string	g_input_gain_level		
2	HandShake Select	Sequence execution method	string	O		
3	Model ID	Not used	string	0000	Not used	
4	Unit No	Not used	string	00	Not used	
5	Continue Select	Message split method	string	NC	No split	
6	Parameter	Parameter				
	Input Channel Select	Input channel selection	string	0 to 5 6	Beam Channel 1 to 6 Analog Input	
7	End Character	Message end character	binary	0x0d	CR	

(2) Answer

The Answer command format from the ATND1061 is shown below.

g_input_gain_level_0000_00_NC_6,40,40,511,,,1,,,↵

Table 4-24 Answer Command Format

No	item	Description	type	value	value description	remarks	
1	Command	Command string	string	g_input_gain_level			
2	Model ID	Not used	string	0000	Not used		
3	Unit No	Device ID	string	00 to FF	Device ID		
4	Continue Select	Message split method	string	NC	No split		
5	Parameter	Parameter					
	Input Channel Select	Input channel selection	string	0 to 5	Beam Channel 1 to 6		
				6	Analog Input		
	gain						
	Mic	Mic gain	string	0 to 30	+0dB to +30dB	See 6.5 Input Gain Table.	
				0	+0.25dB		
	Line	Line gain	string	1	+0.5dB	For analog input	
	Level	Level	string	0 to 511	-120dB to +10dB	See 6.1 Fader Table.	
	Reserved						
	Reserved	Reserved	string				
	Reserved	Reserved	string				
	Mute	Mute status	string	0	Not muted		
				1	Muted		
	Reserved	Reserved	string				
	Reserved						
Reserved	Reserved	string					
Reserved	Reserved	string					
6	End Character	Message end character	binary	0x0d	CR		

4.3.3 Input Channel Setting Change Request

After receiving the Input Channel Setting Change Request, the ATND1061 sends the processing results to the host via ACK or NAK.

(1) Set Command

The command format of the Input Channel Setting Change Request from the host is shown below.

s_input_channel_settings_S_0000_00_NC_6,1,1,,1,1,1,,,,,,,,,,,,,"ANALOG",,,,,,,,,1,50,60,↓

↓

Table 4-25 Command Format

No	item	Description	type	value	value description	remarks
1	Command	Command string	string	s_input_channel_settings		
2	HandShake Select	Sequence execution method	string	S		
3	Model ID	Not used	string	0000	Not used	
4	Unit No	Not used	string	00	Not used	
5	Continue Select	Message split method	string	NC	No split	
6	Parameter	Parameter				
	Input Channel Select	Input channel selection	string	0 to 5	Beam Channel 1 to 6	
				6	Analog Input	
	source	Input source	string	0	Mic	
				1	Line	Only for analog Ch
	Phantom power	Phantom power	string	0	Off	
				1	On	
	Reserved	Reserved	string			
	Low cut	Low cut	string	0	Off	
				1	On	
	AEC	AEC	string	0	Off	
				1	On	
	Smart Mix	Smart Mix	string	0	Off	
				1	On	
	Reserved	Reserved	string			
	Reserved					
	Reserved	Reserved	string			
	Reserved	Reserved	string			

No	item	Description	type	value	value description	remarks
7	End Character	Message end character	binary	0x0d	CR	

(2) ACK/NAK

See Factory Default Setting Request (2).

4.3.4 Input Channel Setting Acquisition Request

After receiving the Input Channel Setting Acquisition Request, the ATND1061 sends the input settings to the host via Answer.

(1) Get Command

The command format of the Input Channel Setting Acquisition Request from the host is shown below.

g_input_channel_settings_O_0000_00_NC_6_↵

Table 4-26 Command Format

No	item	Description	type	value	value description	remarks
1	Command	Command string	string	g_input_channel_settings		
2	HandShake Select	Sequence execution method	string	O		
3	Model ID	Not used	string	0000	Not used	
4	Unit No	Not used	string	00	Not used	
5	Continue Select	Message split method	string	NC	No split	
6	Parameter Input Channel Select	Parameter Input channel selection	string	0 to 5	Beam Channel 1 to 6	
				6	Analog Input	
7	End Character	Message end character	binary	0x0d	CR	

No	item	Description	type	value	value description	remarks	
	Reserved	Reserved	Reserved	string			
		Reserved	Reserved	string			
		Reserved	Reserved	string			
		Reserved	Reserved	string			
		Reserved	Reserved	string			
	Name	Channel name	char	“		Beginning of character string	
			string	ASCII code		Name	To contain double quotation marks (“), specify them in succession like “”.
			char	”		End of character string	
	Color	Channel color	string	0		Green	
				1		Yellow	
				2		Brown	
				3		Red	
				4		Pink	
				5		Blue	
				6		Gray	
				7		DarkGray	
	Reserved	Reserved	Reserved	Reserved	string		
			Reserved	Reserved	string		
			Reserved	Reserved	string		
			Reserved	Reserved	string		
		Reserved	Reserved	string			
		Reserved	Reserved	string			
		Reserved	Reserved	string			
Reserved		Reserved	string				
6	End Character	Message end character	binary	0x0d	CR		

4.3.5 Input EQ Setting Change Request

After receiving the Input EQ Setting Change Request, the ATND1061 sends the processing results to the host via ACK or NAK.

(1) Set Command

The command format of the Input EQ Setting Change Request from the host is shown below.

s_input_eq_S_0000_00_NC_6,1,,2,480,72,31,,480,72,31,,480,72,31,,2,480,72,31,1_↓

Table 4-28 Command Format

No	item	Description	type	value	value description	remarks
1	Command	Command string	string	s_input_eq		
2	HandShake Select	Sequence execution method	string	S		
3	Model ID	Not used	string	0000	Not used	
4	Unit No	Not used	string	00	Not used	
5	Continue Select	Message split method	string	NC	No split	
6	Parameter	Parameter				
	Input Channel Select	Input channel selection	string	0 to 5	Beam Channel 1 to 6	
				6	Analog Input	
	EQ On/Off	On/Off for the whole EQ CH	string	0	Off	
				1	On	
	Band1					
	Reserved	Reserved	string			
	Filter Type	Type of filter	string	0	LPF/HPF	
				1	LSH/HSB	
				2	PEQ	
	Frequency	Frequency	string	0 to 480	20 Hz to 20 kHz	See 6.2 Frequency Table.
	Gain	Gain	string	0 to 72	-18 dB to +18 dB	See 6.4 EQ Gain Table.
	Q Value	Value of Q	string	0 to 31	0.3 to 60	See 6.3 Q Value Table.
	Band2					
	Reserved	Reserved	string			
	Frequency	Frequency	string	0 to 480	20 Hz to 20 kHz	See 6.2 Frequency Table.
	Gain	Gain	string	0 to 72	-18 dB to +18 dB	See 6.4 EQ Gain Table.
	Q Value	Value of Q	string	0 to 31	0.3 to 60	See 6.3 Q Value Table.
	Band3					
	Band4					
	EQ Mode	EQ mode	string	0	Easy Mode	
				1	Expert Mode	

No	item	Description	type	value	value description	remarks
7	End Character	Message end character	binary	0x0d	CR	

(2) ACK/NAK

See Factory Default Setting Request (2).

4.3.6 Input EQ Setting Acquisition Request

After receiving the Input EQ Setting Acquisition Request, the ATND1061 sends the input settings to the host via Answer.

(1) Get Command

The command format of the Input EQ Setting Acquisition Request from the host is shown below.

g_input_eq_O_0000_00_NC_0_↵

Table 4-29 Command Format

No	item	Description	type	value	value description	remarks
1	Command	Command string	string	g_input_eq		
2	HandShake Select	Sequence execution method	string	O		
3	Model ID	Not used	string	0000	Not used	
4	Unit No	Not used	string	00	Not used	
5	Continue Select	Message split method	string	NC	No split	
6	Parameter Input Channel Select	Parameter Input channel selection	string	0 to 5	Beam Channel 1 to 6	
				6	Analog Input	
7	End Character	Message end character	binary	0x0d	CR	

(2) Answer

The Answer command format from the ATND1061 is shown below.

g_input_eq_0000_00_NC_6,1,1,2,480,72,31,1,480,72,31,1,480,72,31,1,2,480,72,31,1_↵

Table 4-30 Answer Command Format

No	item	Description	type	value	value description	remarks
1	Command	Command string	string	g_input_eq		
2	Model ID	Not used	string	0000	Not used	
3	Unit No	Device ID	string	00 to FF	Device ID	
4	Continue Select	Message split method	string	NC	No split	
5	Parameter Input Channel Select	Parameter Input channel selection	string	0 to 5	Beam Channel 1 to 6	

No	item	Description	type	value	value description	remarks
				6	Analog Input	
	EQ On/Off	On/Off for the whole EQ CH	string	0	Off	
				1	On	
	Band1					
	Band Enable	Enable	string	0	Off	
				1	On	
	Filter Type	Type of filter	string	0	LPF/HPF	
				1	LSH/HSH	
				2	PEQ	
	Frequency	Frequency	string	0 to 480	20 Hz to 20 kHz	See 6.2 Frequency Table.
	Gain	Gain	string	0 to 72	-18 dB to +18 dB	See 6.4 EQ Gain Table.
	Q Value	Value of Q	string	0 to 31	0.3 to 60	See 6.3 Q Value Table.
	Band2					
	Band Enable	Enable	string	0	Off	
				1	On	
	Frequency	Frequency	string	0 to 480	20 Hz to 20 kHz	See 6.2 Frequency Table.
	Gain	Gain	string	0 to 72	-18 dB to +18 dB	See 6.4 EQ Gain Table.
	Q Value	Value of Q	string	0 to 31	0.3 to 60	See 6.3 Q Value Table.
	Band3					
	Band4					
	EQ Mode	EQ mode	string	0	Easy Mode	
				1	Expert Mode	
6	End Character	Message end character	binary	0x0d	CR	

4.3.7 Gain Share Setting Change Request

After receiving the Gain Share Setting Change Request, the ATND1061 sends the processing results to the host via ACK or NAK.

(1) Set Command

The command format of the Gain Share Setting Change Request from the host is shown below.

s_smart_mix_S_0000_00_NC_5,,60,,,,↵

Table 4-31 Command Format

No	item	Description	type	value	value description	remarks
1	Command	Command string	string	s_smart_mix		
2	HandShake Select	Sequence execution method	string	S		
3	Model ID	Not used	string	0000	Not used	
4	Unit No	Not used	string	00	Not used	
5	Continue Select	Message split method	string	NC	No split	
6	Parameter	Parameter				
	Input Channel Select	Input channel selection	string	0 to 5	Beam Channel 1 to 6	
	Reserved	Reserved	string			
	Gain Share					
	Weight	Weight of Gain Share	string	0 to 60	-15.0, -14.5 to +15.0	
	Reserved					
	Reserved	Reserved	string			
	Reserved	Reserved	string			
7	End Character	Message end character	binary	0x0d	CR	

(2) ACK/NAK

See Factory Default Setting Request (2).

4.3.8 Gain Share Setting Acquisition Request

After receiving the Gain Share Setting Acquisition Request, the ATND1061 sends the input settings to the host via Answer.

(1) Get Command

The command format of the Gain Share Setting Acquisition Request from the host is shown below.

g_smart_mix_O_0000_00_NC_5_↵

Table 4-32 Command Format

No	item	Description	type	value	value description	remarks
1	Command	Command string	string	g_smart_mix		
2	HandShake Select	Sequence execution method	string	O		
3	Model ID	Not used	string	0000	Not used	
4	Unit No	Not used	string	00	Not used	
5	Continue Select	Message split method	string	NC	No split	
6	Parameter	Parameter				
	Input Channel Select	Input channel selection	string	0 to 5	Beam Channel 1 to 6	
7	End Character	Message end character	binary	0x0d	CR	

(2) Answer

The Answer command format from the ATND1061 is shown below.

g_smart_mix_0000_00_NC_5,,60,,,,_↵

Table 4-33 Answer Command Format

No	item	Description	type	value	value description	remarks
1	Command	Command string	string	g_smart_mix		
2	Model ID	Not used	string	0000	Not used	
3	Unit No	Device ID	string	00 to FF	Device ID	
4	Continue Select	Message split method	string	NC	No split	
5	Parameter	Parameter				
	Input Channel Select	Input channel selection	string	0 to 5	Beam Channel 1 to 6	
	Reserved	Reserved	string			
	Gain Share					
	Weight	Weight of Gain Share	string	0 to 60	-15.0, -14.5 to +15.0	
	Reserved					
	Reserved	Reserved	string			
	Reserved	Reserved	string			
	Reserved	Reserved	string			
6	End Character	Message end character	binary	0x0d	CR	

4.3.9 AEC Setting Change Request

After receiving the AEC Setting Change Request, the ATND1061 sends the processing results to the host via ACK or NAK.

(1) Set Command

The command format of the AEC Setting Change Request from the host is shown below.

s_aec_general_S_0000_00_NC_2,1,,,0,,20,20,1,1,␣

Table 4-34 Command Format

No	item	Description	type	value	value description	remarks	
1	Command	Command string	string	s_aec_genera l			
2	HandShake Select	Sequence execution method	string	S			
3	Model ID	Not used	string	0000	Not used		
4	Unit No	Not used	string	00	Not used		
5	Continue Select	Message split method	string	NC	No split		
6	Parameter	Parameter					
	AEC Enable	AEC status	string	0	Off		
				1	On		
	AEC Reference	AEC Reference	string	0	AnalogInput		
				1	Digital Input		
	Reserved	Reserved	string				
	Reserved	Reserved	string				
	Reserved	Reserved	string				
	Reserved	Reserved	string				
	Noise Canceling Attenuation Level						
	Reserved	Reserved	string				
	Noise Canceling	Attenuation level (Noise Canceling mode)	string	0 to 20	0 to 20 dB		
	Non Linear Processing						
	Enable	Permission of Non-Linear Processing	string	0	Off		
				1	On		
	Sensitivity	Non Linear Processing Sensitivity	string	0	Low		
				1	Mid		
2				High			

No	item	Description	type	value	value description	remarks
	Reserved	Reserved	string			
	NC Enable	NC status	string	0	Off	
				1	On	
7	End Character	Message end character	binary	0x0d	CR	

(2) ACK/NAK

See Factory Default Setting Request (2).

4.3.10 AEC Setting Acquisition Request

After receiving the AEC Setting Acquisition Request, the ATND1061 sends the AEC settings to the host via Answer.

(1) Get Command

The command format of the AEC Setting Acquisition Request from the host is shown below.

`g_aec_general_O_0000_00_NC_␣`

Table 4-35 Command Format

No	item	Description	type	value	value description	remarks
1	Command	Command string	string	g_aec_genera l		
2	HandShake Select	Sequence execution method	string	O		
3	Model ID	Not used	string	0000	Not used	
4	Unit No	Not used	string	00	Not used	
5	Continue Select	Message split method	string	NC	No split	
6	Parameter	Parameter	-	-	No parameter	
7	End Character	Message end character	binary	0x0d	CR	

(2) Answer

The Answer command format from the ATND1061 is shown below.

`g_aec_general_0000_00_NC_2,1,,,0,,20,20,1,1,␣`

Table 4-36 Answer Command Format

No	item	Description	type	value	value description	remarks
1	Command	Command string	string	g_aec_genera l		
2	Model ID	Not used	string	0000	Not used	
3	Unit No	Device ID	string	00 to FF	Device ID	
4	Continue Select	Message split method	string	NC	No split	
5	Parameter	Parameter				
	AEC Enable	AEC status	string	0 1	Off On	
	AEC Reference	AEC Reference	string	0	AnalogInput	
				1	Digital Input	

No	item	Description	type	value	value description	remarks	
	Reserved	Reserved	string				
	Reserved	Reserved	string				
	Reserved	Reserved	string				
	Reserved	Reserved	string				
	Noise Canceling Attenuation Level						
	Reserved	Reserved	string				
	Noise Canceling	Attenuation level (Noise Canceling mode)	string	0 to 20	0 to 20 dB		
	Non Linear Processing						
	Enable	Permission of Non-Linear Processing	string	0	Off		
				1	On		
				2	High		
	Sensitivity	Non Linear Processing Sensitivity	string	0	Low		
				1	Mid		
				2	High		
	Reserved	Reserved	string				
NC Enable	NC status	string	0	Off			
			1	On			
6	End Character	Message end character	binary	0x0d	CR		

4.3.11 AGC Setting Change Request

After receiving the AGC Setting Change Request, the ATND1061 sends the processing results to the host via ACK or NAK.

(1) Set Command

The command format of the AGC Setting Change Request from the host is shown below.

s_agc_S_0000_00_NC_1,,2_↵

Table 4-37 Command Format

No	item	Description	type	value	value description	remarks
1	Command	Command string	string	s_agc		
2	HandShake Select	Sequence execution method	string	S		
3	Model ID	Not used	string	0000	Not used	
4	Unit No	Not used	string	00	Not used	
5	Continue Select	Message split method	string	NC	No split	
6	Parameter	Parameter				
	Enable	Enable	string	0 1	Off On	
	Reserved	Reserved	string			
	Target Level	Target Level	string	-10 to 10	-10 dB to 10 dB	
7	End Character	Message end character	binary	0x0d	CR	

(2) ACK/NAK

See Factory Default Setting Request (2).

4.3.12 AGC Setting Acquisition Request

After receiving the AGC Setting Acquisition Request, the ATND1061 sends the AGC settings to the host via Answer.

(1) Get Command

The command format of the AGC Setting Acquisition Request from the host is shown below.

g_agc_O_0000_00_NC_↵

Table 4-38 Command Format

No	item	Description	type	value	value description	remarks
1	Command	Command string	string	g_agc		
2	HandShake Select	Sequence execution method	string	O		
3	Model ID	Not used	string	0000	Not used	
4	Unit No	Not used	string	00	Not used	
5	Continue Select	Message split method	string	NC	No split	
6	Parameter	Parameter	-	-	No parameter	
7	End Character	Message end character	binary	0x0d	CR	

(2) Answer

The Answer command format from the ATND1061 is shown below.

g_agc_0000_00_NC_1,,2_↵

Table 4-39 Answer Command Format

No	item	Description	type	value	value description	remarks
1	Command	Command string	string	g_agc		
2	Model ID	Not used	string	0000	Not used	
3	Unit No	Device ID	string	00 to FF	Device ID	
4	Continue Select	Message split method	string	NC	No split	
5	Parameter	Parameter				
	Enable	Enable	string	0 1	Off On	
	Reserved	Reserved	string			
	Target Level	Target Level	string	-10 to 10	-10 dB to 10 dB	
6	End Character	Message end character	binary	0x0d	CR	

4.3.13 Gain Share Mode Change Request

After receiving the Gain Share Mode Change Request, the ATND1061 sends the processing results to the host via ACK or NAK.

(1) Set Command

The command format of the Gain Share Mode Change Request from the host is shown below.

s_gainshare_mode_S_0000_00_NC_1_↓

Table 4-40 Command Format

No	item	Description	type	value	value description	remarks
1	Command	Command string	string	s_gainshare_mode		
2	HandShake Select	Sequence execution method	string	S		
3	Model ID	Not used	string	0000	Not used	
4	Unit No	Not used	string	00	Not used	
5	Continue Select	Message split method	string	NC	No split	
6	Parameter	Parameter	string	0	Standalone	
				1	Link	
7	End Character	Message end character	binary	0x0d	CR	

(2) ACK/NAK

See Factory Default Setting Request (2).

4.3.14 Gain Share Mode Acquisition Request

After receiving the Gain Share Mode Acquisition Request, the ATND1061 sends the Gain Share Mode settings to the host via Answer.

(1) Get Command

The command format of the Gain Share Mode Acquisition Request from the host is shown below.

```
g_gainshare_mode_O_0000_00_NC_↵
```

Table 4-41 Command Format

No	item	Description	type	value	value description	remarks
1	Command	Command string	string	g_gainshare_mode		
2	HandShake Select	Sequence execution method	string	O		
3	Model ID	Not used	string	0000	Not used	
4	Unit No	Not used	string	00	Not used	
5	Continue Select	Message split method	string	NC	No split	
6	Parameter	Parameter	-	-	No parameter	
7	End Character	Message end character	binary	0x0d	CR	

(2) Answer

The Answer command format from the ATND1061 is shown below.

```
g_gainshare_mode_0000_00_NC_1_↵
```

Table 4-42 Answer Command Format

No	item	Description	type	value	value description	remarks
1	Command	Command string	string	g_gainshare_mode		
2	Model ID	Not used	string	0000	Not used	
3	Unit No	Device ID	string	00 to FF	Device ID	
4	Continue Select	Message split method	string	NC	No split	
5	Parameter	Parameter				
		Mode	string	0 1	Standalone Link	
6	End Character	Message end character	binary	0x0d	CR	

4.3.15 Voice Lift Setting Change Request

After receiving the Voice Lift Setting Change Request, the ATND1061 sends the processing results to the host via ACK or NAK.

(1) Set Command

The command format of the Voice Lift Setting Change Request from the host is shown below.

s_voicelift_S_0000_00_NC_5_↵

Table 4-43 Command Format

No	item	Description	type	value	value description	remarks
1	Command	Command string	string	s_voicelift		
2	HandShake Select	Sequence execution method	string	S		
3	Model ID	Not used	string	0000	Not used	
4	Unit No	Not used	string	00	Not used	
5	Continue Select	Message split method	string	NC	No split	
6	Parameter	Parameter				
	Processing	Processing Level	string	1 to 5		
7	End Character	Message end character	binary	0x0d	CR	

(2) ACK/NAK

See Factory Default Setting Request (2).

4.3.16 Voice Lift Setting Acquisition Request

After receiving the Voice Lift Setting Acquisition Request, the ATND1061 sends the Voice Lift settings to the host via Answer.

(1) Get Command

The command format of the Voice Lift Setting Acquisition Request from the host is shown below.

g_voicelift_O_0000_00_NC_↵

Table 4-44 Command Format

No	item	Description	type	value	value description	remarks
1	Command	Command string	string	g_voicelift		
2	HandShake Select	Sequence execution method	string	O		
3	Model ID	Not used	string	0000	Not used	
4	Unit No	Not used	string	00	Not used	
5	Continue Select	Message split method	string	NC	No split	
6	Parameter	Parameter	-	-	No parameter	
7	End Character	Message end character	binary	0x0d	CR	

(2) Answer

The Answer command format from the ATND1061 is shown below.

g_voicelift_0000_00_NC_5_↵

Table 4-45 Answer Command Format

No	item	Description	type	value	value description	remarks
1	Command	Command string	string	g_voicelift		
2	Model ID	Not used	string	0000	Not used	
3	Unit No	Device ID	string	00 to FF	Device ID	
4	Continue Select	Message split method	string	NC	No split	
5	Parameter	Parameter				
	Processing	Processing Level	string	1 to 5		
6	End Character	Message end character	binary	0x0d	CR	

4.3.17 Voice Lift Channel Setting Change Request

After receiving the Voice Lift Channel Setting Change Request, the ATND1061 sends the processing results to the host via ACK or NAK.

(1) Set Command

The command format of the Voice Lift Channel Setting Change Request from the host is shown below.

s_voicelift_channel_settings_S_0000_00_NC_30,511,1,"VOICE LIFT",7↵

Table 4-46 Command Format

No	item	Description	type	value	value description	remarks		
1	Command	Command string	string	s_voicelift_channel_settings				
2	HandShake Select	Sequence execution method	string	S				
3	Model ID	Not used	string	0000	Not used			
4	Unit No	Not used	string	00	Not used			
5	Continue Select	Message split method	string	NC	No split			
6	Parameter	Parameter						
		gain	Mic gain	string	0 to 30	0dB to +30dB	See 6.5 Input Gain Table.	
		Level	Level	string	0 to 511	-120dB to +10dB	See 6.1 Fader Table.	
		Mute	Mute status	string	0	Not muted		
					1	Muted		
		Name	Channel name	char	"	Beginning of character string		
					string	ASCII code	Name	To contain double quotation marks ("), specify them in succession like "".
					char	"	End of character string	
		Color	Channel color	string	0	Green		
					1	Yellow		
					2	Brown		
					3	Red		
					4	Pink		
5	Blue							
6	Gray							
7	DarkGray							
7	End Character	Message end character	binary	0x0d	CR			

(2) ACK/NAK

See Factory Default Setting Request (2).

4.3.18 Voice Lift Channel Setting Acquisition Request

After receiving the Voice Lift Channel Setting Acquisition Request, the ATND1061 sends the Voice Lift channel settings to the host via Answer.

(1) Get Command

The command format of the Voice Lift Channel Setting Acquisition Request from the host is shown below.

`g_voicelift_channel_settings_O_0000_00_NC_␣`

Table 4-47 Command Format

No	item	Description	type	value	value description	remarks
1	Command	Command string	string	g_voicelift_channel_settings		
2	HandShake Select	Sequence execution method	string	O		
3	Model ID	Not used	string	0000	Not used	
4	Unit No	Not used	string	00	Not used	
5	Continue Select	Message split method	string	NC	No split	
6	Parameter	Parameter	-	-	No parameter	
7	End Character	Message end character	binary	0x0d	CR	

(2) Answer

The Answer command format from the ATND1061 is shown below.

g_voicelift_channel_settings_0000_00_NC_30,511,1,"VOICE LIFT",7_↵

Table 4-48 Answer Command Format

No	item	Description	type	value	value description	remarks	
1	Command	Command string	string	g_input_channel_settings			
2	Model ID	Not used	string	0000	Not used		
3	Unit No	Device ID	string	00 to FF	Device ID		
4	Continue Select	Message split method	string	NC	No split		
5	Parameter	Parameter					
	gain	Mic gain	string	0 to 30	0dB to +30dB	See 6.5 Input Gain Table.	
	Level	Level	string	0 to 511	-120dB to +10dB	See 6.1 Fader Table.	
	Mute	Mute status	string	0	Not muted		
				1	Muted		
	Name	Channel name	char	"	Beginning of character string		
				string	ASCII code	Name	To contain double quotation marks ("), specify them in succession like "".
				char	"	End of character string	
	Color	Channel color	string	0	Green		
				1	Yellow		
2				Brown			
3				Red			
4				Pink			
5				Blue			
6				Gray			
7	DarkGray						
6	End Character	Message end character	binary	0x0d	CR		

4.3.19 Voice Lift EQ Setting Change Request

After receiving the Voice Lift EQ Setting Change Request, the ATND1061 sends the processing results to the host via ACK or NAK.

(1) Set Command

The command format of the Voice Lift EQ Setting Change Request from the host is shown below.

s_voicelift_eq_S_0000_00_NC_1,,2,480,72,31,,480,72,31,,480,72,31,,2,480,72,31,1_↵

Table 4-49 Command Format

No	item	Description	type	value	value description	remarks	
1	Command	Command string	string	s_voicelift_eq			
2	HandShake Select	Sequence execution method	string	S			
3	Model ID	Not used	string	0000	Not used		
4	Unit No	Not used	string	00	Not used		
5	Continue Select	Message split method	string	NC	No split		
6	Parameter	Parameter					
	EQ On/Off	On/Off for the whole EQ CH	string	0 1	Off On		
	Band1						
	Reserved	Reserved	string				
	Filter Type	Type of filter	string	0	LPF/HPF		
				1	LSH/HSB		
				2	PEQ		
	Frequency	Frequency	string	0 to 480	20 Hz to 20 kHz	See 6.2 Frequency Table.	
	Gain	Gain	string	0 to 72	-18 dB to +18 dB	See 6.4 EQ Gain Table.	
	Q Value	Value of Q	string	0 to 31	0.3 to 60	See 6.3 Q Value Table.	
	Band2						
	Reserved	Reserved	string				
	Frequency	Frequency	string	0 to 480	20 Hz to 20 kHz	See 6.2 Frequency Table.	
	Gain	Gain	string	0 to 72	-18 dB to +18 dB	See 6.4 EQ Gain Table.	
	Q Value	Value of Q	string	0 to 31	0.3 to 60	See 6.3 Q Value Table.	
	Band3						Same as Band2
	Band4						Same as Band1

No	item	Description	type	value	value description	remarks
	EQ Mode	EQ mode	string	0	Easy Mode	
				1	Expert Mode	
7	End Character	Message end character	binary	0x0d	CR	

(2) ACK/NAK

See Factory Default Setting Request (2).

4.3.20 Voice Lift EQ Setting Acquisition Request

After receiving the Voice Lift EQ Setting Acquisition Request, the ATND1061 sends the Voice Lift EQ settings to the host via Answer.

(1) Get Command

The command format of the Voice Lift EQ Setting Acquisition Request from the host is shown below.

```
g_voicelift_eq_O_0000_00_NC_␣
```

Table 4-50 Command Format

No	item	Description	type	value	value description	remarks
1	Command	Command string	string	g_voicelift_eq		
2	HandShake Select	Sequence execution method	string	O		
3	Model ID	Not used	string	0000	Not used	
4	Unit No	Not used	string	00	Not used	
5	Continue Select	Message split method	string	NC	No split	
6	Parameter	Parameter	-	-	No parameter	
7	End Character	Message end character	binary	0x0d	CR	

(2) Answer

The Answer command format from the ATND1061 is shown below.

```
g_voicelift_eq_0000_00_NC_1,1,2,480,72,31,1,480,72,31,1,480,72,31,1,2,480,72,31,1_␣
```

Table 4-51 Answer Command Format

No	item	Description	type	value	value description	remarks
1	Command	Command string	string	g_voicelift_eq		
2	Model ID	Not used	string	0000	Not used	
3	Unit No	Device ID	string	00 to FF	Device ID	
4	Continue Select	Message split method	string	NC	No split	
5	Parameter	Parameter				
	EQ On/Off	On/Off for the whole EQ CH	string	0	Off	
				1	On	
	Band1					
	Band Enable	Enable	string	0	Off	
1				On		

No	item	Description	type	value	value description	remarks	
	Filter Type	Type of filter	string	0	LPF/HPF		
				1	LSH/HSB		
				2	PEQ		
	Frequency	Frequency	string	0 to 480	20 Hz to 20 kHz	See 6.2 Frequency Table.	
	Gain	Gain	string	0 to 72	-18 dB to +18 dB	See 6.4 EQ Gain Table.	
	Q Value	Value of Q	string	0 to 31	0.3 to 60	See 6.3 Q Value Table.	
	Band2						
	Band Enable	Enable	string	0	Off		
				1	On		
	Frequency	Frequency	string	0 to 480	20 Hz to 20 kHz	See 6.2 Frequency Table.	
	Gain	Gain	string	0 to 72	-18 dB to +18 dB	See 6.4 EQ Gain Table.	
	Q Value	Value of Q	string	0 to 31	0.3 to 60	See 6.3 Q Value Table.	
	Band3						Same as Band2
	Band4						Same as Band1
	EQ Mode	EQ mode	string	0	Easy Mode		
1				Expert Mode			
6	End Character	Message end character	binary	0x0d	CR		

4.3.21 Voice Lift Output Select Setting Change Request

After receiving the Voice Lift Output Select Setting Change Request, the ATND1061 sends the processing results to the host via ACK or NAK.

(1) Set Command

The command format of the Voice Lift Output Select Setting Change Request from the host is shown below.

s_voicelift_outputselect_S_0000_00_NC_3_↵

Table 4-52 Command Format

No	item	Description	type	value	value description	remarks		
1	Command	Command string	string	s_voicelift_outputselect				
2	HandShake Select	Sequence execution method	string	S				
3	Model ID	Not used	string	0000	Not used			
4	Unit No	Not used	string	00	Not used			
5	Continue Select	Message split method	string	NC	No split			
6	Parameter	Parameter	string					
				Voice Lift Output Select	Voice Lift Output Select	0	Coverage&Priority	
						1	Coverage	
						2	Priority	
7	End Character	Message end character	binary	0x0d	CR			

(2) ACK/NAK

See Factory Default Setting Request (2).

4.3.22 Voice Lift Output Select Setting Acquisition Request

After receiving the Voice Lift Output Select Setting Acquisition Request, the ATND1061 sends the Voice Lift Output Select settings to the host via Answer.

(1) Get Command

The command format of the Voice Lift Output Select Setting Acquisition Request from the host is shown below.

g_voicelift_outputselect_O_0000_00_NC_↓

Table 4-53 Command Format

No	item	Description	type	value	value description	remarks
1	Command	Command string	string	g_voicelift_outputselect		
2	HandShake Select	Sequence execution method	string	O		
3	Model ID	Not used	string	0000	Not used	
4	Unit No	Not used	string	00	Not used	
5	Continue Select	Message split method	string	NC	No split	
6	Parameter	Parameter	-	-	No parameter	
7	End Character	Message end character	binary	0x0d	CR	

(2) Answer

The Answer command format from the ATND1061 is shown below.

g_voicelift_outputselect_0000_00_NC_5_↵

Table 4-54 Answer Command Format

No	item	Description	type	value	value description	remarks
1	Command	Command string	string	g_voicelift_outputselect		
2	Model ID	Not used	string	0000	Not used	
3	Unit No	Device ID	string	00 to FF	Device ID	
4	Continue Select	Message split method	string	NC	No split	
5	Parameter	Parameter				
	Voice Lift Output Select	Voice Lift Output Select	string	0	Coverage&Priority	
				1	Coverage	
2				Priority		
6	End Character	Message end character	binary	0x0d	CR	

4.4 Output Command Details

4.4.1 Output Level Setting Change Request

After receiving the

Output Level Setting Change Request, the ATND1061 sends the processing results to the host via ACK or NAK.

(1) Set Command

The command format of the

Output Level Setting Change Request from the host is shown below.

s_output_level_S_0000_00_NC_0,511,,,,↵

Table 4-55 Command Format

No	item	Description	type	value	value description	remarks	
1	Command	Command string	string	s_output_level			
2	HandShake Select	Sequence execution method	string	S			
3	Model ID	Not used	string	0000	Not used		
4	Unit No	Not used	string	00	Not used		
5	Continue Select	Message split method	string	NC	No split		
6	Parameter	Parameter					
	Output Channel Select	Output channel selection	string	0	Analog Out		
				1	Auto Mix		
	Level	Level	string	0 to 511	-120dB to +10dB	See 6.1 Fader Table.	
	Reserved						
	Reserved	Reserved	string				
	Reserved	Reserved	string				
	Reserved						
	Reserved	Reserved	string				
	Reserved	Reserved	string				
7	End Character	Message end character	binary	0x0d	CR		

(2) ACK/NAK

See Factory Default Setting Request (2).

4.4.2 Output Level Setting Acquisition Request

After receiving the Output Level Setting Acquisition Request, the ATND1061 sends output settings to the host via Answer.

(1) Get Command

The command format of the Output Level Setting Acquisition Request from the host is shown below.

g_output_level_O_0000_00_NC_0_↵

Table 4-56 Command Format

No	item	Description	type	value	value description	remarks
1	Command	Command string	string	g_output_level		
2	HandShake Select	Sequence execution method	string	O		
3	Model ID	Not used	string	0000	Not used	
4	Unit No	Not used	string	00	Not used	
5	Continue Select	Message split method	string	NC	No split	
6	Parameter Output Channel Select	Parameter Output channel selection	string	0	Analog Out	
				1	Auto Mix	
7	End Character	Message end character	binary	0x0d	CR	

(2) Answer

The Answer command format from the ATND1061 is shown below.

g_output_level_0000_00_NC_0,511,,,,↵

Table 4-57 Answer Command Format

No	item	Description	type	value	value description	remarks	
1	Command	Command string	string	g_output_level			
2	Model ID	Not used	string	0000	Not used		
3	Unit No	Device ID	string	00 to FF	Device ID		
4	Continue Select	Message split method	string	NC	No split		
5	Parameter	Parameter					
	Output Channel Select	Output channel selection	string	0	Analog Out		
				1	Auto Mix		
	Level	Level	string	0 to 511	-120dB to +10dB	See 6.1 Fader Table.	
	Reserved						
	Reserved	Reserved	string				
	Reserved	Reserved	string				
	Reserved						
	Reserved	Reserved	string				
	Reserved	Reserved	string				
6	End Character	Message end character	binary	0x0d	CR		

4.4.3 Output Channel Mute Setting Change Request

After receiving the Output Channel Mute Setting Change Request, the ATND1061 sends the processing results to the host via ACK or NAK.

(1) Set Command

The command format of the Output Channel Mute Setting Change Request from the host is shown below.

s_output_mute_S_0000_00_NC_0,1_↵

Table 4-58 Command Format

No	item	Description	type	value	value description	remarks
1	Command	Command string	string	s_output_mute		
2	HandShake Select	Sequence execution method	string	S		
3	Model ID	Not used	string	0000	Not used	
4	Unit No	Not used	string	00	Not used	
5	Continue Select	Message split method	string	NC	No split	
6	Parameter	Parameter				
	Output Channel Select	Output channel selection	string	0	Analog Out	
				1	Auto Mix	
	Mute	Mute status	string	0	Not muted	
1				Muted		
7	End Character	Message end character	binary	0x0d	CR	

(2) ACK/NAK

See Factory Default Setting Request (2).

4.4.4 Output Channel Mute Setting Acquisition Request

After receiving the Output Channel Mute Setting Acquisition Request, the ATND1061 sends output settings to the host via Answer.

(1) Get Command

The command format of the Output Channel Mute Setting Acquisition Request from the host is shown below.

g_output_mute_O_0000_00_NC_0_↵

Table 4-59 Command Format

No	item	Description	type	value	value description	remarks
1	Command	Command string	string	g_output_mute		
2	HandShake Select	Sequence execution method	string	O		
3	Model ID	Not used	string	0000	Not used	
4	Unit No	Not used	string	00	Not used	
5	Continue Select	Message split method	string	NC	No split	
6	Parameter Output Channel Select	Parameter Output channel selection				
			string	0	Analog Out	
				1	Auto Mix	
7	End Character	Message end character	binary	0x0d	CR	

(2) Answer

The Answer command format from the ATND1061 is shown below.

g_output_mute_0000_00_NC_0,1_↵

Table 4-60 Answer Command Format

No	item	Description	type	value	value description	remarks			
1	Command	Command string	string	g_output_mute					
2	Model ID	Not used	string	0000	Not used				
3	Unit No	Device ID	string	00 to FF	Device ID				
4	Continue Select	Message split method	string	NC	No split				
5	Parameter	Parameter							
				Output Channel Select	Output channel selection	string	0	Analog Out	
							1	Auto Mix	
				Mute	Mute status	string	0	Not muted	
	1	Muted							
6	End Character	Message end character	binary	0x0d	CR				

4.4.5 Output Channel Setting Change Request

After receiving the Output Channel Setting Change Request, the ATND1061 sends the processing results to the host via ACK or NAK.

(1) Set Command

The command format of the Output Channel Setting Change Request from the host is shown below.

s_output_channel_settings_S_0000_00_NC_0,3,"OUT 1",,,,,↵

Table 4-61 Command Format

No	item	Description	type	value	value description	remarks
1	Command	Command string	string	s_output_channel_settings		
2	HandShake Select	Sequence execution method	string	S		
3	Model ID	Not used	string	0000	Not used	
4	Unit No	Not used	string	00	Not used	
5	Continue Select	Message split method	string	NC	No split	
6	Parameter	Parameter				
	Output Channel Select	Output channel selection	string	0	Analog Out	
				1	Auto Mix	
	Unity	Unity	string	0	+4dBu	
				2	-10dBv	
				3	-33dBv	
	Name	Channel name	char	"	Beginning of character string	
			string	ASCII code	Name	To contain double quotation marks ("), specify them in succession like "".
			char	"	End of character string	
	Reserved	Reserved	string			
	Reserved	Reserved	string			
Reserved	Reserved	string				
Reserved	Reserved	string				
7	End Character	Message end character	binary	0x0d	CR	

(2) ACK/NAK

See Factory Default Setting Request (2).

4.4.6 Output Channel Setting Acquisition Request

After receiving the Output Channel Setting Acquisition Request, the ATND1061 sends output settings to the host via Answer.

(1) Get Command

The command format of the Output Channel Setting Acquisition Request from the host is shown below.

`g_output_channel_settings_O_0000_00_NC_0_↵`

Table 4-62 Command Format

No	item	Description	type	value	value description	remarks
1	Command	Command string	string	g_output_channel_settings		
2	HandShake Select	Sequence execution method	string	O		
3	Model ID	Not used	string	0000	Not used	
4	Unit No	Not used	string	00	Not used	
5	Continue Select	Message split method	string	NC	No split	
6	Parameter	Parameter	string	0	Analog Out	
				1	Auto Mix	
7	End Character	Message end character	binary	0x0d	CR	

(2) Answer

The Answer command format from the ATND1061 is shown below.

`g_output_channel_settings_0000_00_NC_0,3,"OUT 1",FFFFFF,1,13_↵`

Table 4-63 Answer Command Format

No	item	Description	type	value	value description	remarks	
1	Command	Command string	string	g_output_channel_settings			
2	Model ID	Not used	string	0000	Not used		
3	Unit No	Device ID	string	00 to FF	Device ID		
4	Continue Select	Message split method	string	NC	No split		
5	Parameter	Parameter					
	Output Channel Select	Output channel selection	string	0	Analog Out		
				1	Auto Mix		
	Unity	Unity	string	0	+4dBu		
				2	-10dBv		
				3	-33dBv		
	Name	Channel name	char	"	Beginning of character string		
					ASCII code	Name	To contain double quotation marks ("), specify them in succession like "".
				"	End of character string		
	Reserved	Reserved	string				
	Reserved	Reserved	string				
Reserved	Reserved	string					
Reserved	Reserved	string					
6	End Character	Message end character	binary	0x0d	CR		

4.5 System Command Details

4.5.1 Factory Default Setting Request

After receiving the Factory Default Setting Request, the ATND1061 sends the processing results to the host via ACK or NAK.

(1) Set Command

The command format of the Factory Default Setting Request from the host is shown below.

```
factory_settings_S_0000_00_NC_0_↵
```

Table 4-64 Command Format

No	item	Description	type	value	value description	remarks
1	Command	Command string	string	factory_settings		
2	HandShake Select	Sequence execution method	string	S		
3	Model ID	Not used	string	0000	Not used	
4	Unit No	Not used	string	00	Not used	
5	Continue Select	Message split method	string	NC	No split	
6	Parameter	Parameter				
	Reset Item	Reset items				
	All Setting to Default.	All settings	string	0	All Reset	Can be omitted
7	End Character	Message end character	binary	0x0d	CR	

(2) ACK/NAK

factory_settings_ACK_↵

Table 4-65 Command Format

No	item	Description	type	value	value description	remarks
1	Command	Command string	string	factory_settings		Sets the received Set/Get command
2	ACK	ACK	string	ACK		
3	End Character	Message end character	binary	0x0d	CR	

factory_settings_NAK_01_↵

Table 4-66 Command Format

No	item	Description	type	value	value description	remarks
1	Command	Command string	string	factory_settings		Sets the received Set/Get command
2	NAK	NAK	string	NAK		
3	Error Code	Error code	string	00 to 99	Error code	See Chapter 2.2.4.
4	End Character	Message end character	binary	0x0d	CR	

4.5.2 Permission Setting Change Request

After receiving the Permission Setting Change Request, the ATND1061 sends the processing results to the host via ACK or NAK.

(1) Set Command

The command format of the Permission Setting Change Request from the host is shown below.

s_permission_S_0000_00_NC_“ATND1061”,0,↵

Table 4-67 Command Format

No	item	Description	type	value	value description	remarks	
1	Command	Command string	string	s_permission			
2	HandShake Select	Sequence execution method	string	S			
3	Model ID	Not used	string	0000	Not used		
4	Unit No	Not used	string	00	Not used		
5	Continue Select	Message split method	string	NC	No split		
6	Parameter	Parameter					
	Device Name	Device name	char	“	Beginning of character string		
			string	ASCII code	Device name	To contain double quotation marks (“), specify them in succession like “”.	
			char	”	End of character string		
	Reserved						
		Reserved	Reserved	string			
		Reserved	Reserved	string			
	Reserved						
		Reserved	Reserved	string			
		Reserved	Reserved	string			
	Reserved						
		Reserved	Reserved	string			
		Reserved	Reserved	string			
		Reserved	Reserved	string			
		Reserved	Reserved	string			
		Reserved	Reserved	string			
	7	End Character	Message end character	binary	0x0d	CR	

(2) ACK/NAK

See Factory Default Setting Request (2).

4.5.3 Permission Setting Acquisition Request

After receiving the Permission Setting Acquisition Request, the ATND1061 sends the permission settings to the host via Answer.

(1) Get Command

The command format of the Permission Setting Acquisition Request from the host is shown below.

g_permission_O_0000_00_NC_↵

Table 4-68 Command Format

No	item	Description	type	value	value description	remarks
1	Command	Command string	string	g_permission		
2	HandShake Select	Sequence execution method	string	O		
3	Model ID	Not used	string	0000	Not used	
4	Unit No	Not used	string	00	Not used	
5	Continue Select	Message split method	string	NC	No split	
6	Parameter	Parameter	-	-	No parameter	
7	End Character	Message end character	binary	0x0d	CR	

(2) Answer

The Answer command format from the ATND1061 is shown below.

g_permission_0000_00_NC_ "ATDM-1012",0,↓

Table 4-69 Answer Command Format

No	item	Description	type	value	value description	remarks	
1	Command	Command string	string	g_permission			
2	Model ID	Not used	string	0000	Not used		
3	Unit No	Device ID	string	00 to FF	Device ID		
4	Continue Select	Message split method	string	NC	No split		
5	Parameter	Parameter	string				
	Device Name	Device name	char	"	Beginning of character string		
			string	ASCII code	Device name	To contain double quotation marks ("), specify them in succession like "".	
			char	"	End of character string		
	Reserved						
		Reserved	Reserved	string			
		Reserved	Reserved	string			
	Reserved						
		Reserved	Reserved	string			
		Reserved	Reserved	string			
	Reserved						
		Reserved	Reserved	string			
		Reserved	Reserved	string			
		Reserved	Reserved	string			
		Reserved	Reserved	string			
	6	End Character	Message end character	binary	0x0d	CR	

4.5.4 Network Setting Change Request

After receiving the Network Setting Change Request, the ATND1061 sends the processing results to the host via ACK or NAK. If the network settings are changed, the ATND1061 needs to be rebooted.

(1) Set Command

The command format of the Network Setting Change Request from the host is shown below.

```
s_network_S_0000_00_NC_1,192.168.033.102,255.255.000.000,,1,17300,1,1,239.000.000.100,17000,0,,,,0,,,,1_↵
```

Table 4-70 Command Format

No	item	Description	type	value	value description	remarks
1	Command	Command string	string	s_network		
2	HandShake Select	Sequence execution method	string	S		
3	Model ID	Not used	string	0000	Not used	
4	Unit No	Not used	string	00	Not used	
5	Continue Select	Message split method	string	NC	No split	
6	Parameter	Parameter				
	IP setting					
	IP config mode	IP address resolution method	string	0 1	Auto Static	
	IP address	IP address	string	000.000.000.000 to 255.255.255.255	IP address	
	Subnet mask	Subnet mask	string	000.000.000.000 to 255.255.255.255	Subnet mask	
	Gateway address	Default gateway	string	000.000.000.000 to 255.255.255.255	Default gateway	
	Allow Discovery	UPnP status	string	0	Not detected	
				1	Detected	
	IP control setting					
	Port Number	TCP/IP port number	string	1 to 65535	Port number	
	Notification	Information transmission status	string	0	Not used	
				1	Used	

No	item	Description	type	value	value description	remarks	
	Audio Level Notification	Audio Level information transmission status	string	0	Not used		
				1	Used		
	Multicast address	Multicast group address	string	000.000.000.000 to 255.255.255.255	IP address		
	Multicast port number	Multicast port number	string	1 to 65535	Port number		
	NTP setting						
	Enabled	NTP use status	string	0	Not used		
				1	Used		
	NTP server address	NTP server address	string	000.000.000.000 to 255.255.255.255	IP address		
	NTP port number	NTP server port number	string	1 to 65535	Port number		
	Time Zone	Difference from GMT	string	-1200 to +1400	±HHMM (in units of 30 minutes)		
	Daylight saving time	Daylight saving time	string	0	Not used		
				1	Used		
	Start Date	Start date of daylight saving time	string	01010000 to 12312300	MMDDHHmm (Units: 1 hour)		
	End Date	End date of daylight saving time	string	01010000 to 12312300	MMDDHHmm (Units: 1 hour)		
	Reserved						
	Reserved	Reserved	string				
	Reserved	Reserved	string				
IP control setting							
Camera Control Notification	Camera Control Notification	Camera Control Notification transmission status	string	0	Not used		
				1	Used		
7	End Character	Message end character	binary	0x0d	CR		

(2) ACK/NAK

See Factory Default Setting Request (2).

4.5.5 Network Setting Acquisition Request

After receiving the Network Setting Acquisition Request, the ATND1061 sends the network settings to the host via Answer.

(1) Get Command

The command format of the Network Setting Acquisition Request from the host is shown below.

g_network_O_0000_00_NC_↓

Table 4-71 Command Format

No	item	Description	type	value	value description	remarks
1	Command	Command string	string	g_network		
2	HandShake Select	Sequence execution method	string	O		
3	Model ID	Not used	string	0000	Not used	
4	Unit No	Not used	string	00	Not used	
5	Continue Select	Message split method	string	NC	No split	
6	Parameter	Parameter	-	-	No parameter	
7	End Character	Message end character	binary	0x0d	CR	

(2) Answer

The Answer command format from the ATND1061 is shown below.

```
g_network_0000_00_NC_1,,,,0005CDC102FA,1,17300,1,1,239.000.000.100,17000,0,,,,0,,
,,,1_
```

Table 4-72 Answer Command Format

No	item	Description	type	value	value description	remarks
1	Command	Command string	string	s_network		
2	Model ID	Not used	string	0000	Not used	
3	Unit No	Device ID	string	00 to FF	Device ID	
4	Continue Select	Message split method	string	NC	No split	
5	Parameter	Parameter				
	IP setting					
	IP config mode	IP address resolution method	string	0 1	Auto Static	
	IP address	IP address	string	000.000.000.000 to 255.255.255.255	IP address	
	Subnet mask	Subnet mask	string	000.000.000.000 to 255.255.255.255	Subnet mask	
	Gateway address	Default gateway	string	000.000.000.000 to 255.255.255.255	Default gateway	
	MAC address	MAC address	string	XXXXXXXXXXXX	MAC address	
	Allow Discovery	UPnP status	string	0	Not detected	
				1	Detected	
	IP control setting					
	Port Number	TCP/IP port number	string	1 to 65535	Port number	
	Notification	Information transmission status	string	0	Not used	
				1	Used	
	Audio Level Notification	Audio Level information transmission status	string	0	Not used	
				1	Used	

No	item	Description	type	value	value description	remarks	
		Multicast address	Multicast group address	string	000.000.000.000 to 255.255.255.255	IP address	
		Multicast port number	Multicast port number	string	1 to 65535	Port number	
	NTP setting						
		Enabled	NTP use status	string	0 1	Not used Used	
		NTP server address	NTP server address	string	000.000.000.000 to 255.255.255.255	IP address	
		NTP port number	NTP server port number	string	1 to 65535	Port number	
		Time Zone	Difference from GMT	string	-1200 to +1400	±HHMM (in units of 30 minutes)	
		Daylight saving time	Daylight saving time	string	0 1	Not used Used	
		Start Date	Start date of daylight saving time	string	01010000 to 12312300	MMDDHHmm (Units: 1 hour)	
		End Date	End date of daylight saving time	string	01010000 to 12312300	MMDDHHmm (Units: 1 hour)	
	Reserved						
		Reserved	Reserved	string			
		Reserved	Reserved	string			
	IP control setting						
		Camera Control Notification	Camera Control Notification transmission status	string	0 1	Not used Used	
6	End Character	Message end character	binary	0x0d	CR		

4.5.6 Dante Setting Change Request

After receiving the Dante Setting Change Request, the ATND1061 sends the processing results to the host via ACK or NAK.

If the Dante settings are changed, the ATND1061 needs to be rebooted.

(1) Set Command

The command format of the Dante Setting Change Request from the host is shown below.

```
s_network_dante_S_0000_00_NC_0,5,1,192.168.033.102,255.255.000.000,,,1,192.168.033.103,255.255.000.000,,↵
```

Table 4-73 Command Format

No	item	Description	type	value	value description	remarks
1	Command	Command string	string	s_network_dante		
2	HandShake Select	Sequence execution method	string	S		
3	Model ID	Not used	string	0000	Not used	
4	Unit No	Not used	string	00	Not used	
5	Continue Select	Message split method	string	NC	No split	
6	Parameter	Parameter				
	Network Configuration					
	Mode	Mode	string	0	Single Cable	
				2	Split	
	Latency	Latency	string	1	250usec	
				2	500usec	
				3	1msec	
				4	2msec	
				5	5msec	
	Port Setting/Primary					
	IP Config mode	IP address acquisition method	string	0	Auto	
				1	Static	
	IP address	IP address	string	000.000.000.000 to 255.255.255.255	IP address	
	Subnet mask	Subnet mask	string	000.000.000.000 to 255.255.255.255	Subnet mask	

No	item	Description	type	value	value description	remarks
		Gateway address	string	000.000.000.000 to 255.255.255.255	IP address	
		Reserved	string			
	Port Setting/Secondary	Secondary settings				Same as Primary
7	End Character	Message end character	binary	0x0d	CR	

(2) ACK/NAK

See Factory Default Setting Request (2).

4.5.7 Dante Setting Acquisition Request

After receiving the Dante Setting Acquisition Request, the ATND1061 sends the network settings to the host via Answer.

(1) Get Command

The command format of the Dante Setting Acquisition Request from the host is shown below.

```
g_network_dante_O_0000_00_NC_␣
```

Table 4-74 Command Format

No	item	Description	type	value	value description	remarks
1	Command	Command string	string	g_network_dante		
2	HandShake Select	Sequence execution method	string	O		
3	Model ID	Not used	string	0000	Not used	
4	Unit No	Not used	string	00	Not used	
5	Continue Select	Message split method	string	NC	No split	
6	Parameter	Parameter	-	-	No parameter	
7	End Character	Message end character	binary	0x0d	CR	

(2) Answer

The Answer command format from the ATND1061 is shown below.

```
g_network_dante_0000_00_NC_0,5,1,192.168.033.102,255.255.000.000,,,1,192.168.033.103,255.255.000.000,,␣
```

Table 4-75 Command Format

No	item	Description	type	value	value description	remarks
1	Command	Command string	string	g_network_dante		
2	Model ID	Not used	string	0000	Not used	
3	Unit No	Device ID	string	00 to FF	Device ID	
4	Continue Select	Message split method	string	NC	No split	
5	Parameter	Parameter				
	Network					

No	item	Description	type	value	value description	remarks
	Configuration					
	Mode	Mode	string	0	Single Cable	
				2	Split	
	Latency	Latency	string	1	250usec	
				2	500usec	
				3	1msec	
				4	2msec	
				5	5msec	
	Port Setting/Primary	Primary settings				
	IP Config mode	IP address acquisition method	string	0	Auto	
				1	Static	
	IP address	IP address	string	000.000.000.000 to 255.255.255.255	IP address	
	Subnet mask	Subnet mask	string	000.000.000.000 to 255.255.255.255	Subnet mask	
	Gateway address	Default gateway	string	000.000.000.000 to 255.255.255.255	IP address	
	Reserved	Reserved	string			
	Port Setting/Secondary	Secondary settings				Same as Primary
6	End Character	Message end character	binary	0x0d	CR	

4.5.8 Firmware Version Acquisition Request

After receiving the Firmware Version Acquisition Request, the ATND1061 sends the device firmware version to the host via Answer.

(1) Get Command

The command format of the Firmware Version Acquisition Request from the host is shown below.

g_firmware_version_O_0000_00_NC_↵

Table 4-76 Command Format

No	item	Description	type	value	value description	remarks
1	Command	Command string	string	g_firmware_version		
2	HandShake Select	Sequence execution method	string	O		
3	Model ID	Not used	string	0000	Not used	
4	Unit No	Not used	string	00	Not used	
5	Continue Select	Message split method	string	NC	No split	
6	Parameter	Parameter	-	-	No parameter	
7	End Character	Message end character	binary	0x0d	CR	

(2) Answer

The Answer command format from the ATND1061 is shown below.

g_firmware_version_0000_00_NC_01.00.00_↵

Table 4-77 Answer Command Format

No	item	Description	type	value	value description	remarks
1	Command	Command string	string	g_firmware_version		
2	Model ID	Not used	string	0000	Not used	
3	Unit No	Device ID	string	00 to FF	Device ID	
4	Continue Select	Message split method	string	NC	No split	
5	Parameter	Parameter				
	version	Version	string	XX.XX.XX	Version	
6	End Character	Message end character	binary	0x0d	CR	

4.5.9 Device Color Setting Change Request

After receiving the Device Color Setting Change Request, the ATND1061 sends the processing results to the host via ACK or NAK.

(1) Get Command

The command of the Device Color Setting Change Request from the host is shown below.

s_header_color_S_0000_00_NC_8_↵

Table 4-78 Command Format

No	item	Description	type	value	value description	remarks
1	Command	Command string	string	s_header_color		
2	HandShake Select	Sequence execution method	string	S		
3	Model ID	Not used	string	0000	Not used	
4	Unit No	Not used	string	00	Not used	
5	Continue Select	Message split method	string	NC	No split	
6	Parameter	Parameter	string	0	Green	
				1	Yellow	
				3	Red	
				4	Pink	
				5	Blue	
				8	Cyan	
7	End Character	Message end character	binary	0x0d	CR	

(2) ACK/NAK

See Factory Default Setting Request (2).

4.5.10 Device Color Setting Acquisition Request

After receiving the Device Color Setting Acquisition Request, the ATND1061 sends the header color settings to the host via Answer.

(1) Get Command

The command of the Device Color Setting Acquisition Request from the host is shown below.

g_header_color_O_0000_00_NC_↵

Table 4-79 Command Format

No	item	Description	type	value	value description	remarks
1	Command	Command string	string	g_header_color		
2	HandShake Select	Sequence execution method	string	O		
3	Model ID	Not used	string	0000	Not used	
4	Unit No	Not used	string	00	Not used	
5	Continue Select	Message split method	string	NC	No split	
6	Parameter	Parameter	-	-	No parameter	
7	End Character	Message end character	binary	0x0d	CR	

(2) Answer

The Answer command format from the ATND1061 is shown below.

g_header_color_0000_00_NC_8_↵

Table 4-80 Answer Command Format

No	item	Description	type	value	value description	remarks
1	Command	Command string	string	g_header_color		
2	Model ID	Not used	string	0000	Not used	
3	Unit No	Device ID	string	00 to FF	Device ID	
4	Continue Select	Message split method	string	NC	No split	
5	Parameter Header Color	Parameter Header color	string	0	Green	
				1	Yellow	
				3	Red	
				4	Pink	
				5	Blue	
				8	Cyan	
6	End Character	Message end character	binary	0x0d	CR	

4.5.11 Log Setting Change Request

After receiving the Log Setting Change Request, the ATND1061 sends the processing results to the host via ACK or NAK.

(1) Set Command

The command format of the Log Setting Change Request from the host is shown below.

s_log_S_0000_00_NC_1,2_↵

Table 4-81 Command Format

No	item	Description	type	value	value description	remarks
1	Command	Command string	string	s_log		
2	HandShake Select	Sequence execution method	string	S		
3	Model ID	Not used	string	0000	Not used	
4	Unit No	Not used	string	00	Not used	
5	Continue Select	Message split method	string	NC	No split	
6	Parameter	Parameter	string	0	Disabled	
				1	Enabled	
			string	0	Internal	
				2	Syslog	
7	End Character	Message end character	binary	0x0d	CR	

(2) ACK/NAK

See Factory Default Setting Request (2).

4.5.12 Log Setting Acquisition Request

After receiving the Log Setting Acquisition Request, the ATND1061 sends the log settings to the host via Answer.

(1) Get Command

The command format of the Log Setting Acquisition Request from the host is shown below.

g_log_O_0000_00_NC_↵

Table 4-82 Command Format

No	item	Description	type	value	value description	remarks
1	Command	Command string	string	g_log		
2	HandShake Select	Sequence execution method	string	O		
3	Model ID	Not used	string	0000	Not used	
4	Unit No	Not used	string	00	Not used	
5	Continue Select	Message split method	string	NC	No split	
6	Parameter	Parameter	-	-	No parameter	
7	End Character	Message end character	binary	0x0d	CR	

(2) Answer

The Answer command format from the ATND1061 is shown below.

g_log_0000_00_NC_1,2_↵

Table 4-83 Answer Command Format

No	item	Description	type	value	value description	remarks
1	Command	Command string	string	g_log		
2	Model ID	Not used	string	0000	Not used	
3	Unit No	Device ID	string	00 to FF	Device ID	
4	Continue Select	Message split method	string	NC	No split	
5	Parameter	Parameter	string	0	Disabled	
				1	Enabled	
	Output destination	Output destination	string	0	Internal	
				2	Syslog	
6	End Character	Message end character	binary	0x0d	CR	

4.5.13 LED Setting Change Request

After receiving the LED Setting Change Request, the ATND1061 sends the processing results to the host via ACK or NAK.

(1) Set Command

The command format of the LED Setting Change Request from the host is shown below.

s_led_S_0000_00_NC_1,4,10,10,10_↵

Table 4-84 Command Format

No	item	Description	type	value	value description	remarks
1	Command	Command string	string	s_led		
2	HandShake Select	Sequence execution method	string	S		
3	Model ID	Not used	string	0000	Not used	
4	Unit No	Not used	string	00	Not used	
5	Continue Select	Message split method	string	NC	No split	
6	Parameter	Parameter				
	Dimmer	Dimmer	string	0	OFF	
				1	ON	
	Reserved	Reserved	string			
	Power Save Mode	LED color when in Power Save mode	string	0	Black	
				1	Red	
				2	Orange	
				3	Yellow	
				4	Pink	
				5	Purple	
				6	Blue	
				7	Aqua	
				8	Green	
				9	Cyan	
	10	White				
Mute	LED color when muting is enabled	string	0 to 10	Same as in Power Save mode		
Unmute	LED color when muting is disabled	string	0 to 10	Same as in Power Save mode		

No	item	Description	type	value	value description	remarks
7	End Character	Message end character	binary	0x0d	CR	

(2) ACK/NAK

See Factory Default Setting Request (2).

4.5.14 LED Setting Acquisition Request

After receiving the LED Setting Acquisition Request, the ATND1061 sends the log settings to the host via Answer.

(1) Get Command

The command format of the LED Setting Acquisition Request from the host is shown below.

g_led_O_0000_00_NC_↵

Table 4-85 Command Format

No	item	Description	type	value	value description	remarks
1	Command	Command string	string	g_led		
2	HandShake Select	Sequence execution method	string	O		
3	Model ID	Not used	string	0000	Not used	
4	Unit No	Not used	string	00	Not used	
5	Continue Select	Message split method	string	NC	No split	
6	Parameter	Parameter	-	-	No parameter	
7	End Character	Message end character	binary	0x0d	CR	

(2) Answer

The Answer command format from the ATND1061 is shown below.

g_led_0000_00_NC_4,9,0,5_↵

Table 4-86 Answer Command Format

No	item	Description	type	value	value description	remarks
1	Command	Command string	string	g_led		
2	Model ID	Not used	string	0000	Not used	
3	Unit No	Device ID	string	00 to FF	Device ID	
4	Continue Select	Message split method	string	NC	No split	
5	Parameter	Parameter				
	Dimmer	Dimmer	string	0	OFF	
				1	ON	
	Reserved	Reserved	string			
	Power Save Mode	LED color when in Power Save mode	string	0	Black	
				1	Red	
				2	Orange	
				3	Yellow	
				4	Pink	
				5	Purple	
				6	Blue	
				7	Aqua	
				8	Green	
				9	Cyan	
	10	White				
Mute	LED color when muting is enabled	string	0 to 10	Same as in Power Save mode		
Unmute	LED color when muting is disabled	string	0 to 10	Same as in Power Save mode		
6	End Character	Message end character	binary	0x0d	CR	

4.5.15 Preset Call Request

After receiving the Preset Call Request, the ATND1061 sends the processing results to the host via ACK or NAK.

(1) Set Command

The command format of the Preset Call Request from the host is shown below.

```
call_preset_S_0000_00_NC_16_↵
```

Table 4-87 Command Format

No	item	Description	type	value	value description	remarks
1	Command	Command string	string	call_preset		
2	HandShake Select	Sequence execution method	string	S		
3	Model ID	Not used	string	0000	Not used	
4	Unit No	Not used	string	00	Not used	
5	Continue Select	Message split method	string	NC	No split	
6	Parameter	Parameter				
	Bank Number	Bank number	string	1 to 16	Bank 1 to 16	
7	End Character	Message end character	binary	0x0d	CR	

(2) ACK/NAK

See Factory Default Setting Request (2).

4.5.16 Preset Save Request

After receiving the Preset Save Request, the ATND1061 sends the processing results to the host via ACK or NAK.

(1) Set Command

The command format of the Preset Save Request from the host is shown below.

```
save_preset_S_0000_00_NC_16_↵
```

Table 4-88 Command Format

No	item	Description	type	value	value description	remarks
1	Command	Command string	string	save_preset		
2	HandShake Select	Sequence execution method	string	S		
3	Model ID	Not used	string	0000	Not used	
4	Unit No	Not used	string	00	Not used	
5	Continue Select	Message split method	string	NC	No split	
6	Parameter	Parameter				
	Bank Number	Bank number	string	1 to 16	Bank 1 to 16	
7	End Character	Message end character	binary	0x0d	CR	

(2) ACK/NAK

See Factory Default Setting Request (2).

4.5.17 Preset Bank Name Change Request

After receiving the Preset Bank Name Change Request, the ATND1061 sends the processing results to the host via ACK or NAK.

(1) Set Command

The command format of the Preset Bank Name Change Request from the host is shown below.

s_name_bank_S_0000_00_NC_16,"preset 16"

Table 4-89 Command Format

No	item	Description	type	value	value description	remarks
1	Command	Command string	string	s_name_bank		
2	HandShake Select	Sequence execution method	string	S		
3	Model ID	Not used	string	0000	Not used	
4	Unit No	Not used	string	00	Not used	
5	Continue Select	Message split method	string	NC	No split	
6	Parameter	Parameter				
	Bank Number	Bank number	string	1 to 16	Bank 1 to 16	
	Name	Bank name	char	"	Beginning of character string	
			string	ASCII code	Bank name	To contain double quotation marks ("), specify them in succession like "".
char	"	End of character string				
7	End Character	Message end character	binary	0x0d	CR	

(2) ACK/NAK

See Factory Default Setting Request (2).

4.5.18 Preset Bank Name Acquisition Request

After receiving the Preset Bank Name Acquisition Request, the ATND1061 sends the Preset Bank Name Acquisition Request to the host via Answer.

(1) Get Command

The command format of the Preset Bank Name Acquisition Request from the host is shown below.

g_name_bank_O_0000_00_NC_↵

Table 4-90 Command Format

No	item	Description	type	value	value description	remarks
1	Command	Command string	string	g_name_bank		
2	HandShake Select	Sequence execution method	string	O		
3	Model ID	Not used	string	0000	Not used	
4	Unit No	Not used	string	00	Not used	
5	Continue Select	Message split method	string	NC	No split	
6	Parameter	Parameter	-	-	No parameter	
7	End Character	Message end character	binary	0x0d	CR	

(2) Answer

The Answer command format from the ATND1061 is shown below.

g_name_bank_0000_00_CS_1,"preset 1"↵

g_name_bank_0000_00_CM_2,"preset 2"↵

⋮

g_name_bank_0000_00_CM_15,"preset 15"↵

g_name_bank_0000_00_CE_16,"preset 16"↵

Table 4-91 Command Format

No	item	Description	type	value	value description	remarks	
1	Command	Command string	string	g_name_bank			
2	Model ID	Not used	string	0000	Not used		
3	Unit No	Device ID	string	00 to FF	Device ID		
4	Continue Select	Message split method	string	CS/CM/CE	Split		
5	Parameter	Parameter					
		Bank Number	Bank number	string	1 to 16	Bank 1 to 16	
		Name	Bank name	char	"	Beginning of character string	
				string	ASCII code	Bank name	To contain double quotation marks ("), specify them in succession like "".
char	"	End of character string					
6	End Character	Message end character	binary	0x0d	CR		

4.5.19 Boot Up Preset Setting Change Request

After receiving the Boot Up Preset Setting Change Request, the ATND1061 sends the processing results to the host via ACK or NAK.

(1) Set Command

The command format of the Boot Up Preset Setting Change Request from the host is shown below.

s_bootup_preset_S_0000_00_NC_16_↵

Table 4-92 Command Format

No	item	Description	type	value	value description	remarks
1	Command	Command string	string	s_bootup_preset		
2	HandShake Select	Sequence execution method	string	S		
3	Model ID	Not used	string	0000	Not used	
4	Unit No	Not used	string	00	Not used	
5	Continue Select	Message split method	string	NC	No split	
6	Parameter Bank Number	Parameter Bank number	string	0	Not selected	
				1 to 16	Bank 1 to 16	
7	End Character	Message end character	binary	0x0d	CR	

(2) ACK/NAK

See Factory Default Setting Request (2).

4.5.20 Boot Up Preset Setting Acquisition Request

After receiving the Boot Up Preset Setting Acquisition Request, the ATND1061 sends the log settings to the host via Answer.

(1) Get Command

The command format of the Boot Up Preset Setting Acquisition Request from the host is shown below.

g_bootup_preset_O_0000_00_NC_↵

Table 4-93 Command Format

No	item	Description	type	value	value description	remarks
1	Command	Command string	string	g_bootup_preset		
2	HandShake Select	Sequence execution method	string	O		
3	Model ID	Not used	string	0000	Not used	
4	Unit No	Not used	string	00	Not used	
5	Continue Select	Message split method	string	NC	No split	
6	Parameter	Parameter	-	-	No parameter	
7	End Character	Message end character	binary	0x0d	CR	

(2) Answer

The Answer command format from the ATND1061 is shown below.

g_bootup_preset_0000_00_NC_16_↵

Table 4-94 Answer Command Format

No	item	Description	type	value	value description	remarks
1	Command	Command string	string	g_bootup_preset		
2	Model ID	Not used	string	0000	Not used	
3	Unit No	Device ID	string	00 to FF	Device ID	
4	Continue Select	Message split method	string	NC	No split	
5	Parameter	Parameter				
	Bank Number	Bank number	string	0 1 to 16	Not selected Bank 1 to 16	
6	End Character	Message end character	binary	0x0d	CR	

4.5.21 File Transfer Request

After receiving the File Transfer Request, the ATND1061 sends the processing results to the host via ACK or NAK.

(1) Set Command

The command format of the File Transfer Request from the host is shown below.

```
file_transfer_S_0000_00_CS_p1,00000400,1024,[binary data]↵
```

```
file_transfer_S_0000_00_CM_p1,00000800,1024,[binary data]↵
```

```
⋮
```

```
file_transfer_S_0000_00_CM_p1,00001000,1024,[binary data]↵
```

```
file_transfer_S_0000_00_CE_p1,00001400,256,[binary data]↵
```

Table 4-95 Command Format

No	item	Description	type	value	value description	remarks
1	Command	Command string	string	file_transfer		
2	HandShake Select	Sequence execution method	string	S		
3	Model ID	Not used	string	0000	Not used	
4	Unit No	Not used	string	00	Not used	
5	Continue Select	Message split method	string	NC/CS/CM/CE	Split	
6	Parameter	Parameter				
	Kind	Transfer data type	string	See 6.6 Transfer data type.		
	File Offset	Offset	string	00000000 to FFFFFFFF	Specify the offset in the transfer file in HEX. Do not add "0x". A value obtained with ftell (FILE*)	
	Size	Size	string	0001 to 1024	Specify the number of bytes of transfer data in DEC.	
	Data	Transfer data	binary	-	Specify the transfer data in binary.	
7	End Character	Message end character	binary	0x0d	CR	

(2) ACK/NAK

See Factory Default Setting Request (2).

4.5.22 File Transfer Cancel Request

After receiving the File Transfer Cancel Request, the ATND1061 sends the processing results to the host via ACK or NAK.

(1) Set Command

The command format of the File Transfer Cancel Request from the host is shown below.

```
file_transfer_cancel_S_0000_00_NC_p1_↵
```

Table 4-96 Command Format

No	item	Description	type	value	value description	remarks
1	Command	Command string	string	file_transfer_cancel		
2	HandShake Select	Sequence execution method	string	S		
3	Model ID	Not used	string	0000	Not used	
4	Unit No	Not used	string	00	Not used	
5	Continue Select	Message split method	string	NC/CS/CM/CE	Split	
6	Parameter	Parameter				
	Kind	Transfer data type	string	See 6.6 Transfer data type.		
7	End Character	Message end character	binary	0x0d	CR	

(2) ACK/NAK

See Factory Default Setting Request (2).

4.5.23 Export Request

After receiving the Export Request, the ATND1061 sends specified data to the host via ACK or NAK.

(1) Get Command

The command format of the Export Request from the host is shown below.

```
export_O_0000_00_NC_p1_↵
```

Table 4-97 Command Format

No	item	Description	type	value	value description	remarks
1	Command	Command string	string	export		
2	HandShake Select	Sequence execution method	string	O		
3	Model ID	Not used	string	0000	Not used	
4	Unit No	Not used	string	00	Not used	
5	Continue Select	Message split method	string	NC	No split	
6	Parameter	Parameter				
	Kind	Transfer data type	string	See 6.6 Transfer data type.		
7	End Character	Message end character	binary	0x0d	CR	

(2) Answer

The Answer command format from the ATND1061 is shown below.

```
export_0000_00_CS_p1,00000400,1024,[binary data]↵
export_0000_00_CM_p1,00000800,1024,[binary data]↵
.
.
.
export_0000_00_CM_p1,00001000,1024,[binary data]↵
export_0000_00_CE_p1,00001400,256,[binary data]↵
```

Table 4-98 Answer Command Format

No	item	Description	type	value	value description	remarks
1	Command	Command string	string	export		
2	Model ID	Not used	string	0000	Not used	
3	Unit No	Device ID	string	00 to FF	Device ID	
4	Continue Select	Message split method	string	NC/CS/CM/CE	Split	
5	Parameter	Parameter				
	Kind	Transfer data type	string	See 6.6 Transfer data type.		
	File Offset	Offset	string	00000000 to FFFFFFFF	Specify the offset in the transfer file in HEX. Do not add "0x". A value obtained with ftell (FILE*)	
	Size	Size	string	0001 to 1024	Specify the number of bytes of transfer data in DEC.	
	Data	Transfer data	binary	-	Specify the transfer data in binary.	
6	End Character	Message end character	binary	0x0d	CR	

4.5.24 Import Request

After receiving the Import Request, the ATND1061 sends the processing results to the host via ACK or NAK.

After Import Request, use the File Transfer Request command for transfer data.

(1) Set Command

The command format of the Import Request from the host is shown below.

```
import_S_0000_00_NC_p1_↵
```

Table 4-99 Command Format

No	item	Description	type	value	value description	remarks
1	Command	Command string	string	import		
2	HandShake Select	Sequence execution method	string	S		
3	Model ID	Not used	string	0000	Not used	
4	Unit No	Not used	string	00	Not used	
5	Continue Select	Message split method	string	NC	No split	
6	Parameter	Parameter				
	Kind	Transfer data type	string	See 6.6 Transfer data type.		
7	End Character	Message end character	binary	0x0d	CR	

(2) ACK/NAK

See Factory Default Setting Request (2).

4.5.25 Level Meter Notification Interval Change Request

After receiving the Level Meter Notification Interval Change Request, the ATND1061 sends the processing results to the host via ACK or NAK.

(1) Get Command

The command format of the Level Meter Notification Interval Change Request from the host is shown below.

```
s_level_meter_interval_S_0000_00_NC_100_↵
```

Table 4-100 Command Format

No	item	Description	type	value	value description	remarks
1	Command	Command string	string	s_level_meter_interval		
2	HandShake Select	Sequence execution method	string	S		
3	Model ID	Not used	string	0000	Not used	
4	Unit No	Not used	string	00	Not used	
5	Continue Select	Message split method	string	NC	No split	
6	Parameter	Parameter				
	Interval	Notification interval	string	100 to 300000	msec	
7	End Character	Message end character	binary	0x0d	CR	

(2) ACK/NAK

See Factory Default Setting Request (2).

4.5.26 Level Meter Notification Interval Acquisition Request

After receiving the Level Meter Notification Interval Acquisition Request, the ATND1061 sends the Level Meter settings to the host via Answer.

(1) Get Command

The command format of the Level Meter Notification Interval Acquisition Request from the host is shown below.

g_level_meter_interval_O_0000_00_NC_↵

Table 4-101 Command Format

No	item	Description	type	value	value description	remarks
1	Command	Command string	string	g_level_meter_interval		
2	HandShake Select	Sequence execution method	string	O		
3	Model ID	Not used	string	0000	Not used	
4	Unit No	Not used	string	00	Not used	
5	Continue Select	Message split method	string	NC	No split	
6	Parameter	Parameter		-	-	None
7	End Character	Message end character	binary	0x0d	CR	

(2) Answer

The Answer command format from the ATND1061 is shown below.

g_level_meter_interval_0000_00_NC_100_↵

Table 4-102 Answer Command Format

No	item	Description	type	value	value description	remarks
1	Command	Command string	string	g_level_meter_interval		
2	Model ID	Not used	string	0000	Not used	
3	Unit No	Device ID	string	00 to FF	Device ID	
4	Continue Select	Message split method	string	NC	No split	
5	Parameter	Parameter				
	Interval	Notification interval	string	100 to 300000	msec	
6	End Character	Message end character	binary	0x0d	CR	

4.5.27 Talker Position Notification Interval Change Request

After receiving the Talker Position Notification Interval Change Request, the ATND1061 sends the processing results to the host via ACK or NAK.

(1) Get Command

The command format of the Talker Position Notification Interval Change Request from the host is shown below.

```
s_camera_control_interval_S_0000_00_NC_100_↵
```

Table 4-103 Command Format

No	item	Description	type	value	value description	remarks
1	Command	Command string	string	s_camera_control_interval		
2	HandShake Select	Sequence execution method	string	S		
3	Model ID	Not used	string	0000	Not used	
4	Unit No	Not used	string	00	Not used	
5	Continue Select	Message split method	string	NC	No split	
6	Parameter	Parameter				
	Interval	Notification interval	string	100 to 300000	msec	
7	End Character	Message end character	binary	0x0d	CR	

(2) ACK/NAK

See Factory Default Setting Request (2).

4.5.28 Talker Position Notification Interval Acquisition Request

After receiving the Talker Position Notification Interval Acquisition Request, the ATND1061 sends the Level Meter settings to the host via Answer.

(1) Get Command

The command format of the Talker Position Notification Interval Acquisition Request from the host is shown below.

g_camera_control_interval_O_0000_00_NC_↵

Table 4-104 Command Format

No	item	Description	type	value	value description	remarks
1	Command	Command string	string	g_camera_control_interval		
2	HandShake Select	Sequence execution method	string	O		
3	Model ID	Not used	string	0000	Not used	
4	Unit No	Not used	string	00	Not used	
5	Continue Select	Message split method	string	NC	No split	
6	Parameter	Parameter		-	-	None
7	End Character	Message end character	binary	0x0d	CR	

(2) Answer

The Answer command format from the ATND1061 is shown below.

g_talkerposition_interval_0000_00_NC_100_↵

Table 4-105 Answer Command Format

No	item	Description	type	value	value description	remarks
1	Command	Command string	string	g_talkerposition_interval		
2	Model ID	Not used	string	0000	Not used	
3	Unit No	Device ID	string	00 to FF	Device ID	
4	Continue Select	Message split method	string	NC	No split	
5	Parameter	Parameter				
	Interval	Notification interval	string	100 to 300000	msec	
6	End Character	Message end character	binary	0x0d	CR	

4.5.29 Identify Request

After receiving the Identify Request, the ATND1061 sends the processing results to the host via ACK or NAK.

(1) Set Command

The command format of the Identify Request from the host is shown below.

identify_S_0000_00_NC_↵

Table 4-106 Command Format

No	item	Description	type	value	value description	remarks
1	Command	Command string	string	identify		
2	HandShake Select	Sequence execution method	string	S		
3	Model ID	Not used	string	0000	Not used	
4	Unit No	Not used	string	00	Not used	
5	Continue Select	Message split method	string	NC	No split	
6	Parameter	Parameter	-	-	No parameter	
7	End Character	Message end character	binary	0x0d	CR	

(2) ACK/NAK

See Factory Default Setting Request (2).

4.5.30 Date Setting Request

After receiving the Date Setting Request, the ATND1061 sends the processing results to the host via ACK or NAK.

(1) Set Command

The command format of the Date Setting Request from the host is shown below.

s_date_S_0000_00_NC_20190711145000_↵

Table 4-107 Command Format

No	item	Description	type	value	value description	remarks
1	Command	Command string	string	s_date		
2	HandShake Select	Sequence execution method	string	S		
3	Model ID	Not used	string	0000	Not used	
4	Unit No	Not used	string	00	Not used	
5	Continue Select	Message split method	string	NC	No split	
6	Parameter	Parameter				
	Timestamp	Timestamp	string	YYYYMMDDHHMMSS	Date and time (four-digit year)	
7	End Character	Message end character	binary	0x0d	CR	

(2) ACK/NAK

See Factory Default Setting Request (2).

4.5.31 Reboot Request

Upon receiving Reboot Request, the ATND1061 reboots by itself.

(1) Set Command

The command format of the Reboot Request from the host is shown below.

```
reboot_S_0000_00_NC_↵
```

Table 4-108 Command Format

No	item	Description	type	value	value description	remarks
1	Command	Command string	string	reboot		
2	HandShake Select	Sequence execution method	string	S		
3	Model ID	Not used	string	0000	Not used	
4	Unit No	Not used	string	00	Not used	
5	Continue Select	Message split method	string	NC	No split	
6	Parameter	Parameter	-	-	No parameter	
7	End Character	Message end character	binary	0x0d	CR	

(2) ACK/NAK

See Factory Default Setting Request (2).

4.5.32 Device ID Change Request

After receiving the Device ID Change Request, the ATND1061 sends the processing results to the host via ACK or NAK.

(3) Set Command

The command format of the Device ID Change Request from the host is shown below.

```
s_deviceid_S_0000_00_NC_08_↓
```

Table 4-109 Command Format

No	item	Description	type	value	value description	remarks
8	Command	Command string	string	s_deviceid		
9	HandShake Select	Sequence execution method	string	S		
10	Model ID	Not used	string	0000	Not used	
11	Unit No	Not used	string	00	Not used	
12	Continue Select	Message split method	string	NC	No split	
13	Parameter	Parameter				
	Device ID	Device ID	string	00 to FF	Device ID	
14	End Character	Message end character	binary	0x0d	CR	

(4) ACK/NAK

See Factory Default Setting Request (2).

4.5.33 Device ID Acquisition Request

After receiving the Device ID Acquisition Request, the ATND1061 sends the header color settings to the host via Answer.

(3) Get Command

The command of the Device ID Acquisition Request from the host is shown below.

```
g_deviceid_O_0000_00_NC_↓
```

Table 4-110 Command Format

No	item	Description	type	value	value description	remarks
8	Command	Command string	string	g_deviceid		
9	HandShake Select	Sequence execution method	string	O		
10	Model ID	Not used	string	0000	Not used	
11	Unit No	Not used	string	00	Not used	
12	Continue Select	Message split method	string	NC	No split	
13	Parameter	Parameter	-	-	No parameter	
14	End Character	Message end character	binary	0x0d	CR	

(4) Answer

The Answer command format from the ATND1061 is shown below.

```
g_deviceid_0000_00_NC_08_↓
```

Table 4-111 Answer Command Format

No	item	Description	type	value	value description	remarks
7	Command	Command string	string	g_deviceid		
8	Model ID	Not used	string	0000	Not used	
9	Unit No	Device ID	string	00 to FF	Device ID	
10	Continue Select	Message split method	string	NC	No split	
11	Parameter	Parameter				
	Device ID	Device ID	string	00 to FF	Device ID	
12	End Character	Message end character	binary	0x0d	CR	

4.5.34 Preset Number Acquisition Request

After receiving the Preset Number Acquisition Request, the ATND1061 sends the preset bank number to the host via Answer.

(1) Get Command

The command of the Preset Number Acquisition Request from the host is shown below.

g_preset_number_O_0000_00_NC_↓

Table 4-112 Command Format

No	item	Description	type	value	value description	remarks
1	Command	Command string	string	g_preset_number		
2	HandShake Select	Sequence execution method	string	O		
3	Model ID	Not used	string	0000	Not used	
4	Unit No	Not used	string	00	Not used	
5	Continue Select	Message split method	string	NC	No split	
6	Parameter	Parameter	-	-	No parameter	
7	End Character	Message end character	binary	0x0d	CR	

(2) Answer

The Answer command format from the ATND1061 is shown below.

g_preset_number_0000_00_NC_16_↓

Table 4-113 Answer Command Format

No	item	Description	type	value	value description	remarks
1	Command	Command string	string	g_preset_number		
2	Model ID	Not used	string	0000	Not used	
3	Unit No	Device ID	string	00 to FF	Device ID	
4	Continue Select	Message split method	string	NC	No split	
5	Parameter	Parameter				
	Bank Number	Bank number	string	1 to 16	Bank 1 to 16	
6	End Character	Message end character	binary	0x0d	CR	

4.5.35 External Control Setting Change Request

After receiving the External Control Setting Change Request, the ATND1061 sends the processing results to the host via ACK or NAK.

(1) Set Command

The command format of the External Control Setting Change Request from the host is shown below.

s_remotecontrol_S_0000_00_NC_1,1,1,2,2_↵

Table 4-114 Command Format

No	item	Description	type	value	value description	remarks
1	Command	Command string	string	s_remotecontrol		
2	HandShake Select	Sequence execution method	string	S		
3	Model ID	Not used	string	0000	Not used	
4	Unit No	Not used	string	00	Not used	
5	Continue Select	Message split method	string	NC	No split	
6	Parameter	Parameter				
	Remote Controller				IR remote controller setting	
	Power	Power Save Mode	string	0	Not used	
				1	Used	
	Mute	Mute	string	0	Not used	
				1	Used	
	Preset	Preset Recall Link	string	0	Not used	
				1	Used	
	GPI				GPI setting	
	Port 1	GPI port 1	string	0	Power Save Mode	
				1	Mute	
				2	Reboot	
				3	Camera Control	
	Port 2	GPI port 2	string	0 to 3		Same as GPI port 1

No	item	Description	type	value	value description	remarks
7	End Character	Message end character	binary	0x0d	CR	

(2) ACK/NAK

See Factory Default Setting Request (2).

4.5.36 External Control Setting Acquisition Request

After receiving the External Control Setting Acquisition Request, the ATND1061 sends the header color settings to the host via Answer.

(1) Get Command

The command of the External Control Setting Acquisition Request from the host is shown below.

g_remotecontrol_O_0000_00_NC_↵

Table 4-115 Command Format

No	item	Description	type	value	value description	remarks
1	Command	Command string	string	g_remotecontrol		
2	HandShake Select	Sequence execution method	string	O		
3	Model ID	Not used	string	0000	Not used	
4	Unit No	Not used	string	00	Not used	
5	Continue Select	Message split method	string	NC	No split	
6	Parameter	Parameter	-	-	No parameter	
7	End Character	Message end character	binary	0x0d	CR	

(2) Answer

The Answer command format from the ATND1061 is shown below.

g_remotecontrol_0000_00_NC_1,1,1,2,2_↓

Table 4-116 Answer Command Format

No	item	Description	type	value	value description	remarks	
1	Command	Command string	string	g_remotecontrol			
2	Model ID	Not used	string	0000	Not used		
3	Unit No	Device ID	string	00 to FF	Device ID		
4	Continue Select	Message split method	string	NC	No split		
5	Parameter	Parameter					
	Remote Controller					IR remote controller setting	
		Power	Power Save Mode	string	0	Not used	
					1	Used	
		Mute	Mute	string	0	Not used	
	1				Used		
	Preset	Preset Recall Link	string	0	Not used		
				1	Used		
	GPI					GPI setting	
	Port 1	GPI port 1	string	0	Power Save Mode		
				1	Mute		
				2	Reboot		
				3	Camera Control		
	Port 2	GPI port 2	string	0 to 3		Same as GPI port 1	
6	End Character	Message end character	binary	0x0d	CR		

4.5.37 Device Sync Control Change Request

After receiving the Device Sync Control Change Request, the ATND1061 sends the processing results to the host via ACK or NAK.

(1) Set Command

The command format of the Device Sync Control Change Request from the host is shown below.

```
s_syncontrol,S_0000_00_NC_1,1,1,128,,↵
```

Table 4-117 Command Format

No	item	Description	type	value	value description	remarks
1	Command	Command string	string	s_syncontrol		
2	HandShake Select	Sequence execution method	string	S		
3	Model ID	Not used	string	0000	Not used	
4	Unit No	Not used	string	00	Not used	
5	Continue Select	Message split method	string	NC	No split	
6	Parameter	Parameter				
	Power	Power Save Mode	string	0	Not synchronized	
				1	Synchronized	
	Mute	Mute	string	0	Not synchronized	
				1	Synchronized	
	Preset	Preset Recall Link	string	0	Not synchronized	
1				Synchronized		
Group	Group ID	string	1 to 128	Sync group ID		
Reserved	Reserved	string				
7	End Character	Message end character	binary	0x0d	CR	

(2) ACK/NAK

See Factory Default Setting Request (2).

4.5.38 Device Sync Control Acquisition Request

After receiving the Device Sync Control Acquisition Request, the ATND1061 sends the header color settings to the host via Answer.

(1) Get Command

The command of the Device Sync Control Acquisition Request from the host is shown below.

g_syncontrol_O_0000_00_NC_↵

Table 4-118 Command Format

No	item	Description	type	value	value description	remarks
1	Command	Command string	string	g_syncontrol		
2	HandShake Select	Sequence execution method	string	O		
3	Model ID	Not used	string	0000	Not used	
4	Unit No	Not used	string	00	Not used	
5	Continue Select	Message split method	string	NC	No split	
6	Parameter	Parameter	-	-	No parameter	
7	End Character	Message end character	binary	0x0d	CR	

(2) Answer

The Answer command format from the ATND1061 is shown below.

g_syncontrol_0000_00_NC_1,1,1,128,0_↵

Table 4-119 Answer Command Format

No	item	Description	type	value	value description	remarks
1	Command	Command string	string	g_syncontrol		
2	Model ID	Not used	string	0000	Not used	
3	Unit No	Device ID	string	00 to FF	Device ID	
4	Continue Select	Message split method	string	NC	No split	
5	Parameter	Parameter				
	Power	Power Save Mode	string	0	Not synchronized	
				1	Synchronized	
	Mute	Mute	string	0	Not synchronized	
				1	Synchronized	
	Preset	Preset Recall Link	string	0	Not synchronized	
1				Synchronized		
Group	Group ID	string	1 to 128	Sync group ID		
Reserved	Reserved	string				
6	End Character	Message end character	binary	0x0d	CR	

4.5.39 Audio System Setting Change Request

After receiving the Audio System Setting Change Request, the ATND1061 sends the processing results to the host via ACK or NAK.

(1) Set Command

The command format of the Audio System Setting Change Request from the host is shown below.

s_audio_system_S_0000_00_NC,,,,,1,2,1,28,100_↵

Table 4-120 Command Format

No	item	Description	type	value	value description	remarks
1	Command	Command string	string	s_audio_system		
2	HandShake Select	Sequence execution method	string	S		
3	Model ID	Not used	string	0000	Not used	
4	Unit No	Not used	string	00	Not used	
5	Continue Select	Message split method	string	NC	No split	
6	Parameter	Parameter				
	Reserved	Reserved	string			
	Reserved	Reserved	string			
	Reserved	Reserved	string			
	Reserved	Reserved	string			
	Tx6	Dante Tx#6 Signal	string	0 1	Automix Priority 5	
	Beam Sensitivity	Beam Sensitivity	string	0	Low	
				1	Mid	
				2	High	
	Auto Attenuation	Auto Attenuation	string	0	Disabled	
				1	Enabled	
Attenuation Level	Attenuation Level	string	0 to 28	-∞, -30 to -3 dB	See 6.7 Attenuation Level Table.	
Hold Time	Hold Time	string	0 to 100	0 to 10sec	0.1step	
7	End Character	Message end character	binary	0x0d	CR	

(2) ACK/NAK

See Factory Default Setting Request (2).

4.5.40 Audio System Setting Acquisition Request

After receiving the Audio System Setting Acquisition Request, the ATND1061 sends the audio system settings to the host via Answer.

(1) Get Command

The command of the Audio System Setting Acquisition Request from the host is shown below.

g_audio_system_O_0000_00_NC_↵

Table 4-121 Command Format

No	item	Description	type	value	value description	remarks
1	Command	Command string	string	g_audio_system		
2	HandShake Select	Sequence execution method	string	O		
3	Model ID	Not used	string	0000	Not used	
4	Unit No	Not used	string	00	Not used	
5	Continue Select	Message split method	string	NC	No split	
6	Parameter	Parameter	-	-	No parameter	
7	End Character	Message end character	binary	0x0d	CR	

(2) Answer

The Answer command format from the ATND1061 is shown below.

g_audio_system_0000_00_NC,,,,,1,2,1,28,100_↵

Table 4-122 Answer Command Format

No	item	Description	type	value	value description	remarks
1	Command	Command string	string	g_audio_system		
2	Model ID	Not used	string	0000	Not used	
3	Unit No	Device ID	string	00 to FF	Device ID	
4	Continue Select	Message split method	string	NC	No split	
5	Parameter	Parameter				
	Reserved	Reserved	string			
	Reserved	Reserved	string			
	Reserved	Reserved	string			
	Reserved	Reserved	string			
	Tx6	Dante Tx#6 Signal	string	0 1	Automix Priority 5	
	Beam Sensitivity	Beam Sensitivity	string	0	Low	
				1	Mid	
				2	High	
	Auto Attenuation	Auto Attenuation	string	0	Disabled	
1				Enabled		
Attenuation Level	Attenuation Level	string	0 to 28	-∞, -30 to -3 dB	See 6.7 Attenuation Level Table.	
Hold Time	Hold Time	string	0 to 100	0 to 10sec	0.1step	
6	End Character	Message end character	binary	0x0d	CR	

4.5.41 Power Save Mode Request

Upon receiving Power Save Mode Request, the ATND1061 reboots by itself.

(1) Set Command

The command format of the Power Save Mode Request from the host is shown below.

s_powersave_S_0000_00_NC_1_↵

Table 4-123 Command Format

No	item	Description	type	value	value description	remarks
1	Command	Command string	string	s_powersave		
2	HandShake Select	Sequence execution method	string	S		
3	Model ID	Not used	string	0000	Not used	
4	Unit No	Not used	string	00	Not used	
5	Continue Select	Message split method	string	NC	No split	
6	Parameter	Parameter	-	-	No parameter	
	mode	Power Save Mode	string	0	Power save mode is canceled.	
				1	Power save mode is enabled.	
7	End Character	Message end character	binary	0x0d	CR	

(2) ACK/NAK

See Factory Default Setting Request (2).

4.5.42 Device Mute Request

After receiving the Device Mute Request, the ATND1061 sends the processing results to the host via ACK or NAK.

(1) Set Command

The command format of the Device Mute Request from the host is shown below.

```
s_mute_S_0000_00_NC_1_↵
```

Table 4-124 Command Format

No	item	Description	type	value	value description	remarks
1	Command	Command string	string	s_mute		
2	HandShake Select	Sequence execution method	string	S		
3	Model ID	Not used	string	0000	Not used	
4	Unit No	Not used	string	00	Not used	
5	Continue Select	Message split method	string	NC	No split	
6	Parameter	Parameter				
	Mute	Mute status	string	0 1	Not muted Muted	
7	End Character	Message end character	binary	0x0d	CR	

(2) ACK/NAK

See Factory Default Setting Request (2).

4.5.43 Device Mute Status Acquisition Request

After receiving the Device Mute Status Acquisition Request, the ATND1061 sends the device mute status to the host via Answer.

(1) Set Command

The command format of the Device Mute Status Acquisition Request from the host is shown below.

g_mute_O_0000_00_NC_↵

Table 4-125 Command Format

No	item	Description	type	value	value description	remarks
1	Command	Command string	string	g_mute		
2	HandShake Select	Sequence execution method	string	O		
3	Model ID	Not used	string	0000	Not used	
4	Unit No	Not used	string	00	Not used	
5	Continue Select	Message split method	string	NC	No split	
6	Parameter	Parameter		-	-	None
7	End Character	Message end character	binary	0x0d	CR	

(2) Answer

The Answer command format from the ATND1061 is shown below.

g_mute_0000_00_NC_1_↵

Table 4-126 Answer Command Format

No	item	Description	type	value	value description	remarks
1	Command	Command string	string	g_audio_system		
2	Model ID	Not used	string	0000	Not used	
3	Unit No	Device ID	string	00 to FF	Device ID	
4	Continue Select	Message split method	string	NC	No split	
5	Parameter	Parameter				
	Mute	Mute status	string	0 1	Not muted Muted	
6	End Character	Message end character	binary	0x0d	CR	

4.5.44 Dante Tx5 Setting Change Request

After receiving the Dante Tx5 Setting Change Request, the ATND1061 sends the processing results to the host via ACK or NAK.

(1) Set Command

The command format of the Dante Tx5 Setting Change Request from the host is shown below.

```
s_dante_tx5_S_0000_00_NC_1_↓
```

Table 4-127 Command Format

No	item	Description	type	value	value description	remarks
1	Command	Command string	string	s_dante_tx5		
2	HandShake Select	Sequence execution method	string	S		
3	Model ID	Not used	string	0000	Not used	
4	Unit No	Not used	string	00	Not used	
5	Continue Select	Message split method	string	NC	No split	
6	Parameter Tx5	Parameter Dante Tx#5 Signal	string	0	Priority4	
				1	Voice Lift Processing Level 1 output	
7	End Character	Message end character	binary	0x0d	CR	

(2) ACK/NAK

See Factory Default Setting Request (2).

4.5.45 Dante Tx5 Setting Acquisition Request

After receiving the Dante Tx5 Setting Acquisition Request, the ATND1061 sends the audio system settings to the host via Answer.

(1) Get Command

The command of the Dante Tx5 Setting Acquisition Request from the host is shown below.

g_dante_tx5_O_0000_00_NC_↵

Table 4-128 Command Format

No	item	Description	type	value	value description	remarks
1	Command	Command string	string	g_dante_tx5		
2	HandShake Select	Sequence execution method	string	O		
3	Model ID	Not used	string	0000	Not used	
4	Unit No	Not used	string	00	Not used	
5	Continue Select	Message split method	string	NC	No split	
6	Parameter	Parameter	-	-	No parameter	
7	End Character	Message end character	binary	0x0d	CR	

(2) Answer

The Answer command format from the ATND1061 is shown below.

g_dante_tx5_0000_00_NC_1_↵

Table 4-129 Answer Command Format

No	item	Description	type	value	value description	remarks
1	Command	Command string	string	g_dante_tx5		
2	Model ID	Not used	string	0000	Not used	
3	Unit No	Device ID	string	00 to FF	Device ID	
4	Continue Select	Message split method	string	NC	No split	
5	Parameter	Parameter				
	Tx5	Dante Tx#5 Signal	string	0 1	Priority4 Voice Lift Processing Level 1 output	
6	End Character	Message end character	binary	0x0d	CR	

4.5.46 Room Type Setting Change Request

After receiving the Room Type Setting Change Request, the ATND1061 sends the processing results to the host via ACK or NAK.

(1) Set Command

The command format of the Room Type Setting Change Request from the host is shown below.

s_roomtype_S_0000_00_NC_2_↵

Table 4-130 Command Format

No	item	Description	type	value	value description	remarks
1	Command	Command string	string	s_roomtype		
2	HandShake Select	Sequence execution method	string	S		
3	Model ID	Not used	string	0000	Not used	
4	Unit No	Not used	string	00	Not used	
5	Continue Select	Message split method	string	NC	No split	
6	Parameter Room Type	Parameter Room Type	string	0	Dry	
				1	Live	
				2	Reverberant	
7	End Character	Message end character	binary	0x0d	CR	

(2) ACK/NAK

See Factory Default Setting Request (2).

4.5.47 Room Type Setting Acquisition Request

After receiving the Room Type Setting Acquisition Request, the ATND1061 sends the room type settings to the host via Answer.

(1) Get Command

The command of the Room Type Setting Acquisition Request from the host is shown below.

g_roomtype_O_0000_00_NC_↵

Table 4-131 Command Format

No	item	Description	type	value	value description	remarks
1	Command	Command string	string	g_roomtype		
2	HandShake Select	Sequence execution method	string	O		
3	Model ID	Not used	string	0000	Not used	
4	Unit No	Not used	string	00	Not used	
5	Continue Select	Message split method	string	NC	No split	
6	Parameter	Parameter	-	-	No parameter	
7	End Character	Message end character	binary	0x0d	CR	

(2) Answer

The Answer command format from the ATND1061 is shown below.

g_roomtype_0000_00_NC_1_↵

Table 4-132 Answer Command Format

No	item	Description	type	value	value description	remarks
1	Command	Command string	string	g_roomtype		
2	Model ID	Not used	string	0000	Not used	
3	Unit No	Device ID	string	00 to FF	Device ID	
4	Continue Select	Message split method	string	NC	No split	
5	Parameter	Room Type	string	0	Dry	
				1	Live	
				2	Reverberant	
6	End Character	Message end character	binary	0x0d	CR	

4.5.48 Talker Position Information Acquisition Request

After receiving the Talker Position Information Acquisition Request, the ATND1061 sends the talker position information to the host via Answer.

(1) Get Command

The command of the Talker Position Information Acquisition Request from the host is shown below.

g_camera_control_notice_O_0000_00_NC_↵

Table 4-133 Command Format

No	item	Description	type	value	value description	remarks
1	Command	Command string	string	g_camera_control_notice		
2	HandShake Select	Sequence execution method	string	O		
3	Model ID	Not used	string	0000	Not used	
4	Unit No	Not used	string	00	Not used	
5	Continue Select	Message split method	string	NC	No split	
6	Parameter	Parameter	-	-	No parameter	
7	End Character	Message end character	binary	0x0d	CR	

(2) Answer

The Answer command format from the ATND1061 is shown below.

g_camera_control_notice_0000_00_NC_1_↵

Table 4-134 Answer Command Format

No	item	Description	type	value	value description	remarks
1	Command	Command string	string	g_camera_control_notice		
2	Model ID	Not used	string	0000	Not used	
3	Unit No	Device ID	string	00 to FF	Device ID	
4	Continue Select	Message split method	string	NC	No split	
5	Parameter	Parameter				
	Status	Status	string	0	Not in a state of speaking	
				1	In a state of speaking	
	Channel	Channel	string	0 to 5	Beam Channel 1 to 6	Enabled when Status is 1
				Omitted	Out of range	
	Angle	Elevation angle	string	0 to 90		
	Rotate	Rotation angle	string	0 to 360		
CameraNo	Camera area number	string	0	No camera area		
			1 to 15	Camera area number		
6	End Character	Message end character	binary	0x0d	CR	

4.6 Camera Command Details

4.6.1 Camera Device Setting Change Request

After receiving the Camera Device Setting Change Request, the ATND1061 sends the processing results to the host via ACK or NAK.

(1) Set Command

The command format of the Camera Device Setting Change Request from the host is shown below.

s_camera_device_S_0000_00_NC_1,1,192.168.000.010,80,0_↵

Table 4-135 Command Format

No	Item	Description	type	Value	value description	remarks
1	Command	Command string	string	s_camera_device		
2	HandShake Select	Sequence execution method	string	S		
3	Model ID	Not used	string	0000	Not used	
4	Unit No	Not used	string	00	Not used	
5	Continue Select	Message split method	string	NC	No split	
6	Parameter	Parameter				
	Device No.	Device number	string	1	Camera number	
	Enable	Use status	string	0	Not used	
				1	Used	
	IP address	IP address	string	000.000.000.000 to 255.255.255.255	IP address	
	Port Number	Port number	string	1 to 65535	Port number	
Protocol	Protocol	string	0	Panasonic		
			1	VISCA over IP		
7	End Character	Message end character	binary	0x0d	CR	

(2) ACK/NAK

See Factory Default Setting Request (2).

4.6.2 Camera Device Setting Acquisition Request

After receiving the Camera Device Setting Acquisition Request, the ATND1061 sends the camera device settings to Host via Answer.

(1) Set Command

The command format of the Camera Device Setting Acquisition Request from the host is shown below.

g_camera_device_O_0000_00_NC_1_↓

Table 4-136 Command Format

No	item	Description	type	value	value description	remarks
1	Command	Command string	string	g_camera_device		
2	HandShake Select	Sequence execution method	string	O		
3	Model ID	Not used	string	0000	Not used	
4	Unit No	Not used	string	00	Not used	
5	Continue Select	Message split method	string	NC	No split	
6	Parameter	Parameter		-	-	None
	Device No.	Device number	string	1	Camera number	
7	End Character	Message end character	binary	0x0d	CR	

(2) Answer

The Answer command format from the ATND1061 is shown below.

g_camera_device_0000_00_NC_1,1,192.168.000.010,80,0

Table 4-137 Answer Command Format

No	item	Description	type	value	value description	remarks
1	Command	Command string	string	g_camera_device		
2	Model ID	Not used	string	0000	Not used	
3	Unit No	Device ID	string	00 to FF	Device ID	
4	Continue Select	Message split method	string	NC	No split	
5	Parameter	Parameter				
	Device No.	Device number	string	1	Camera number	
	Enable	Use status	string	0	Not used	
				1	Used	
	IP address	IP address	string	000.000.000.000 to 255.255.255.255	IP address	
	Port Number	Port number	string	1 to 65535	Port number	
Protocol	Protocol	string	0	Panasonic		
			1	VISCA over IP		
6	End Character	Message end character	binary	0x0d	CR	

4.6.3 Camera Preset Setting Change Request

After receiving the Camera Preset Setting Change Request, the ATND1061 sends the processing results to the host via ACK or NAK.

(1) Set Command

The command format of the Camera Preset Setting Change Request from the host is shown below.

s_camera_preset_S_0000_00_NC_HOME,1,2,3,4,5,6,7,8,9,10,11,12,13,14,15

Table 4-138 Command Format

No	item	Description	type	value	value description	remarks
1	Command	Command string	string	s_camera_preset		
2	HandShake Select	Sequence execution method	string	S		
3	Model ID	Not used	string	0000	Not used	
4	Unit No	Not used	string	00	Not used	
5	Continue Select	Message split method	string	NC	No split	
6	Parameter	Parameter				
	HOME	Position for silent	string	HOME 1 to 100	HOME Position Preset 1 to Preset 100	
	Group1	Position for Group1	string	1 to 100	Preset 1 to Preset 100	
	Group2	Position for Group2				Same as Group1
	Group3	Position for Group3				Same as Group1
	Group4	Position for Group4				Same as Group1
	Group5	Position for Group5				Same as Group1
	Group6	Position for Group6				Same as Group1
	Group7	Position for Group7				Same as Group1
	Group8	Position for Group8				Same as Group1
	Group9	Position for Group9				Same as Group1
	Group10	Position for Group10				Same as Group1
	Group11	Position for Group11				Same as Group1
	Group12	Position for Group12				Same as Group1
	Group13	Position for Group13				Same as Group1
	Group14	Position for Group14				Same as Group1
Group15	Position for Group15				Same as Group1	

No	item	Description	type	value	value description	remarks
7	End Character	Message end character	binary	0x0d	CR	

(2) ACK/NAK

See Factory Default Setting Request (2).

4.6.4 Camera Preset Setting Acquisition Request

After receiving the Camera Preset Setting Acquisition Request, the ATND1061 sends the camera preset settings to Host via Answer.

(1) Set Command

The command format of the Camera Preset Setting Acquisition Request from the host is shown below.

g_camera_preset_O_0000_00_NC_↵

Table 4-139 Command Format

No	item	Description	type	value	value description	remarks
1	Command	Command string	string	g_camera_preset		
2	HandShake Select	Sequence execution method	string	O		
3	Model ID	Not used	string	0000	Not used	
4	Unit No	Not used	string	00	Not used	
5	Continue Select	Message split method	string	NC	No split	
6	Parameter	Parameter		-	-	None
7	End Character	Message end character	binary	0x0d	CR	

(2) Answer

The Answer command format from the ATND1061 is shown below.

`g_camera_preset_0000_00_NC_HOME,1,2,3,4,5,6,7,8,9,10,11,12,13,14,15_`

Table 4-140 Answer Command Format

No	item	Description	type	value	value description	remarks
1	Command	Command string	string	g_camera_preset		
2	Model ID	Not used	string	0000	Not used	
3	Unit No	Device ID	string	00 to FF	Device ID	
4	Continue Select	Message split method	string	NC	No split	
5	Parameter	Parameter				
	HOME	Position for silent	string	HOME 1 to 100	HOME Position Preset 1 to Preset 100	
	Group1	Position for Group1	string	1 to 100	Preset 1 to Preset 100	
	Group2	Position for Group2				Same as Group1
	Group3	Position for Group3				Same as Group1
	Group4	Position for Group4				Same as Group1
	Group5	Position for Group5				Same as Group1
	Group6	Position for Group6				Same as Group1
	Group7	Position for Group7				Same as Group1
	Group8	Position for Group8				Same as Group1
	Group9	Position for Group9				Same as Group1
	Group10	Position for Group10				Same as Group1
	Group11	Position for Group11				Same as Group1
	Group12	Position for Group12				Same as Group1
	Group13	Position for Group13				Same as Group1
	Group14	Position for Group14				Same as Group1
Group15	Position for Group15				Same as Group1	
6	End Character	Message end character	binary	0x0d	CR	

4.6.5 Camera Control Time Setting Change Request

After receiving the Camera Control Time Setting Change Request, the ATND1061 sends the processing results to the host via ACK or NAK.

(1) Set Command

The command format of the Camera Control Time Setting Change Request from the host is shown below.

s_camera_control_S_0000_00_NC_10000,1,100000_↵

Table 4-141 Command Format

No	item	Description	type	value	value description	remarks
1	Command	Command string	string	s_camera_control		
2	HandShake Select	Sequence execution method	string	S		
3	Model ID	Not used	string	0000	Not used	
4	Unit No	Not used	string	00	Not used	
5	Continue Select	Message split method	string	NC	No split	
6	Parameter	Parameter				
	Time to Recall Preset	Time to recall preset	string	500 to 10000	msec	
	Enable go back Home	Enable go back Home	string	0	Not used	
				1	Used	
Time to go back Home	Time to go back Home	string	500 to 100000	msec		
7	End Character	Message end character	binary	0x0d	CR	

(2) ACK/NAK

See Factory Default Setting Request (2).

4.6.6 Camera Control Time Setting Acquisition Request

After receiving the Camera Control Time Setting Acquisition Request, the ATND1061 sends the processing results to the host via ACK or NAK.

(1) Set Command

The command format of the Camera Control Time Setting Acquisition Request from the host is shown below.

g_camera_control_O_0000_00_NC_↵

Table 4-142 Command Format

No	item	Description	type	value	value description	remarks
1	Command	Command string	string	g_camera_control		
2	HandShake Select	Sequence execution method	string	O		
3	Model ID	Not used	string	0000	Not used	
4	Unit No	Not used	string	00	Not used	
5	Continue Select	Message split method	string	NC	No split	
6	Parameter	Parameter		-	-	None
7	End Character	Message end character	binary	0x0d	CR	

(2) Answer

The Answer command format from the ATND1061 is shown below.

g_camera_control_0000_00_NC_10000,1,100000_↵

Table 4-143 Answer Command Format

No	item	Description	type	value	value description	remarks
1	Command	Command string	string	g_camera_control		
2	Model ID	Not used	string	0000	Not used	
3	Unit No	Device ID	string	00 to FF	Device ID	
4	Continue Select	Message split method	string	NC	No split	
5	Parameter	Parameter				
	Time to Recall Preset	Time to recall preset	string	500 to 10000	msec	
	Enable go back Home	Enable go back Home	string	0	Not used	
				1	Used	
Time to go back Home	Time to go back Home	string	500 to 100000	msec		
6	End Character	Message end character	binary	0x0d	CR	

4.6.7 Camera Control Pause Request

After receiving the Camera Control Pause Request, the ATND1061 sends the processing results to the host via ACK or NAK.

(1) Set Command

The command format of the Camera Control Pause Request from the host is shown below.

s_camera_stop_S_0000_00_NC_1_↵

Table 4-144 Command Format

No	item	Description	type	value	value description	remarks
1	Command	Command string	string	s_camera_stop		
2	HandShake Select	Sequence execution method	string	S		
3	Model ID	Not used	string	0000	Not used	
4	Unit No	Not used	string	00	Not used	
5	Continue Select	Message split method	string	NC	No split	
6	Parameter Stop	Parameter				
		Pause control status	string	0 1	Pause released Paused	
7	End Character	Message end character	binary	0x0d	CR	

(2) ACK/NAK

See Factory Default Setting Request (2).

5 UDP Communications

The information (status change notification) from the ATND1061 is sent via UDP protocol.

5.1 Communication Control

For details on the communication control flow, see Chapter 4.1.

5.1.1 Communication Start

The host registers groups to the multicast address.

Table 5-1 Communication Control Parameters

No	Name	Default Setting	Remarks
1.	IPAddress	239.000.000.100	Multicast address
2.	Port No	17000	

5.1.2 Control Sequence

5.1.2.1 Information

If the ATND1061 status changes, a status change notification is sent.

<Example> The sequence of conference status notification is shown below.

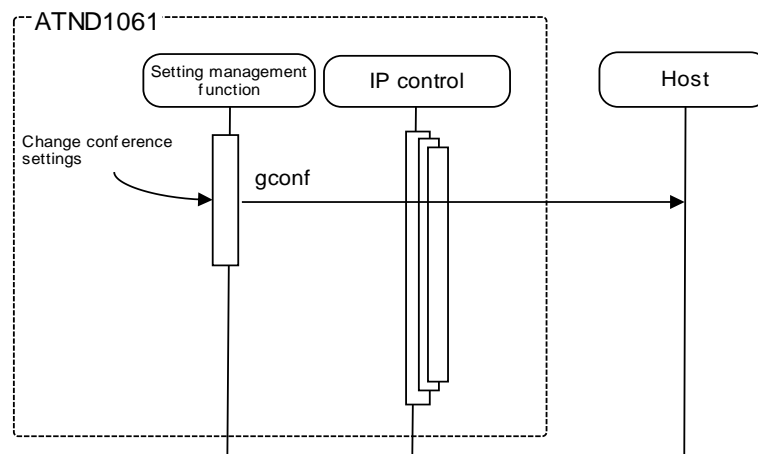

Figure 5-1 Information Command Processing Sequence

5.1.3 Communication Errors

For details on the sequence for transmission errors, see 4.1.3.1.

5.1.4 Communication End

The host can unregister groups at any timing.

No	item	Description	type	value	value description	remarks	
		Level 12	Analog Out	string	0 to 61	Level Meter of Analog Output	
		Level 13	Auto Mix	string	0 to 61	Level Meter of Auto Mix	
		Level 14	Voice Lift	string	0 to 61	Level Meter of Voice Lift Channel	
		Reserved	Reserved	string			
		Reserved	Reserved	string			
		Reserved	Reserved	string			
		Reserved	Reserved	string			
		Reserved	Reserved	string			
		Reserved	Reserved	string			
		Reserved	Reserved	string			
AEC(ERL) Meter							
		Level 22	AEC(ERL)	string	0 to 60	Level Meter of AEC (ERL)	
		Reserved	Reserved	string			
		Reserved	Reserved	string			
		Reserved	Reserved	string			
		Reserved	Reserved	string			
		Reserved	Reserved	string			
		Reserved	Reserved	string			
		Reserved	Reserved	string			
		Reserved	Reserved	string			
Gain Share Meter							
		Level 32	Beam Channel 1	string	0 to 15	Level Meter of Beam Channel 1	
		Level 33	Beam Channel 2	string	0 to 15	Level Meter of Beam Channel 2	
		Level 34	Beam Channel 3	string	0 to 15	Level Meter of Beam Channel 3	
		Level 35	Beam Channel 4	string	0 to 15	Level Meter of Beam Channel 4	
		Level 36	Beam Channel 5	string	0 to 15	Level Meter of Beam Channel 5	
		Level 37	Beam Channel 6	string	0 to 15	Level Meter of Beam Channel 6	
		Reserved	Reserved	string			
		Reserved	Reserved	string			

No	item	Description	type	value	value description	remarks
		Reserved	Reserved	string		
		Reserved	Reserved	string		
7	End Character	Message end character	binary	0x0d	CR	

5.2.2 Input Gain&Level Setting Notification

When the Gain&Level setting of the input channel is changed from the ATND1061, an Input Gain&Level Setting Notification will be sent. It is not sent when IP Control Setting Notification is 0 (not used) in the network setting.

MD_input_gain_level_notice_0000_00_NC_6,40,40,511,1_↓

Table 5-3 Command Format

No	item	Description	type	value	value description	remarks	
1	Modify	MD	string	MD			
2	Command	Command string	string	input_gain_level_notice			
3	Model ID	Not used	string	0000	Not used		
4	Unit No	Device ID	string	00 to FF	Device ID		
5	Continue Select	Message split method	string	NC	No split		
6	Parameter	Parameter					
	Input Channel Select	Input channel selection	string	0 to 5	Input Channel 1 to 6		
				6	Analog		
	gain						
	Mic	Mic gain	string	0 to 40		+20dB to +60dB	See 6.5 Input Gain Table.
				0 to 40		-20dBu to -60dBu	See 6.5 Input Gain Table.
	Line	Line gain	string	0 to 40		-20dBu to -60dBu	See 6.5 Input Gain Table.
Level	Level	string	0 to 511		-120dB to +10dB	See 6.1 Fader Table.	
Mute	Mute status	string	0		Not muted		
			1		Muted		
7	End Character	Message end character	binary	0x0d	CR		

5.2.3 Output Level Setting Notification

When the level setting of the output channel is changed from the ATND1061, an Output Level Setting Notification will be sent.

It is not sent when IP Control Setting Notification is 0 (not used) in the network setting.

MD_output_level_notice_0000_00_NC_0,511_↵

Table 5-4 Command Format

No	item	Description	type	value	value description	remarks
1	Modify	MD	string	MD		
2	Command	Command string	string	output_level_notice		
3	Model ID	Not used	string	0000	Not used	
4	Unit No	Device ID	string	00 to FF	Device ID	
5	Continue Select	Message split method	string	NC	No split	
6	Parameter	Parameter				
	Output Channel Select	Output channel selection	string	0	Analog Out	
				1	Auto Mix	
	Level	Level	string	0 to 511	-120dB to +10dB	See 6.1 Fader Table.
7	End Character	Message end character	binary	0x0d	CR	

5.2.4 Output Channel Mute Setting Notification

When the mute setting of the output channel is changed from the ATND1061, an Output Channel Mute Setting Notification will be given. It is not sent when IP Control Setting Notification is 0 (not used) in the network setting.

MD_output_mute_notice_0000_00_NC_0,1↵

Table 5-5 Command Format

No	item	Description	type	value	value description	remarks
1	Modify	MD	string	MD		
2	Command	Command string	string	output_mute_notice		
3	Model ID	Not used	string	0000	Not used	
4	Unit No	Device ID	string	00 to FF	Device ID	
5	Continue Select	Message split method	string	NC	No split	
6	Parameter	Parameter				
	Output Channel Select	Output channel selection	string	0	Analog Out	
				1	Auto Mix	
	Mute	Mute status	string	0	Not muted	
1				Muted		
7	End Character	Message end character	binary	0x0d	CR	

5.2.5 Preset Call Notification

Preset Call Notification is sent when a preset call is made from the ATND1061.

It is not sent when IP Control Setting Notification is 0 (not used) in the network setting.

MD_recall_preset_notice_0000_00_NC_1_↵

Table 5-6 Command Format

No	item	Description	type	value	value description	remarks
1	Modify	MD	string	MD		
2	Command	Command string	string	recall_preset_notice		
3	Model ID	Not used	string	0000	Not used	
4	Unit No	Device ID	string	00 to FF	Device ID	
5	Continue Select	Message split method	string	NC	No split	
6	Parameter	Parameter				
	Bank Number	Bank number	string	1 to 16	Bank 1 to 16	
7	End Character	Message end character	binary	0x0d	CR	

5.2.6 Talker Position Notification

A Talker Position Notification is sent periodically from the ATND1061.

It is reported at the interval set in the Talker Position Notification Interval Change Request. (The default is 100 msec.)

It is not sent when IP Control Setting Camera Control Notification is 0 (not used) in the network setting.

MD_camera_control_notice_0000_00_NC_1,5,90,360,15_↓

Table 5-7 Command Format

No	item	Description	type	value	value description	remarks
1	Command	Command string	string	camera_control_notice		
2	HandShake Select	Sequence execution method	string	0		
3	Model ID	Not used	string	0000	Not used	
4	Unit No	Device ID	string	00 to FF	Device ID	
5	Continue Select	Message split method	string	NC	No split	
6	Parameter	Parameter				
	Status	Status	string	0	Not in a state of speaking	
				1	In a state of speaking	
	Channel	Channel	string	0 to 5	Beam Channel 1 to 6	Enabled when Status is 1
				Omitted	Out of range	
	Angle	Elevation angle	string	0 to 90		
	Rotate	Rotation angle	string	0 to 360		
CameraNo	Camera area number	string	0	No camera area		
			1 to 15	Camera area number		
7	End Character	Message end character	binary	0x0d	CR	

5.2.7 Power Save Mode Notification

When the status of power save mode of the ATND1061 is changed, a Power Save Mode Notification will be sent. It is not sent when IP Control Setting Notification is 0 (not used) in the network setting.

MD_powersave_notice_0000_00_NC_1↵

Table 5-8 Command Format

No	item	Description	type	value	value description	remarks
1	Command	Command string	string	powersave_notice		
2	HandShake Select	Sequence execution method	string	0		
3	Model ID	Not used	string	0000	Not used	
4	Unit No	Device ID	string	00 to FF	Device ID	
5	Continue Select	Message split method	string	NC	No split	
6	Parameter	Parameter				
	mode	Power Save Mode	string	0	Power save mode canceled	
				1	Power save mode	
7	End Character	Message end character	binary	0x0d	CR	

5.2.8 Device Mute Notification

When the device mute status is changed from the ATND1061, Device Mute Notification will be given.
It is not sent when IP Control Setting Notification is 0 (not used) in the network setting.

MD_mute_notice_0000_00_NC_1↵

Table 5-9 Command Format

No	item	Description	type	value	value description	remarks
1	Modify	MD	string	MD		
2	Command	Command string	string	mute_notice		
3	Model ID	Not used	string	0000	Not used	
4	Unit No	Device ID	string	00 to FF	Device ID	
5	Continue Select	Message split method	string	NC	No split	
6	Parameter	Parameter				
	Mute	Mute status	string	0	Not muted	
				1	Muted	
7	End Character	Message end character	binary	0x0d	CR	

6 Appendix

6.1 Fader Table

Value	Data[dB]	Value	Data[dB]	Value	Data[dB]	Value	Data[dB]	Value	Data[dB]	Value	Data[dB]	Value	Data[dB]	Value	Data[dB]
0	-Infinity	64	-63.5	128	-36.6	192	-23.8	256	-15.5	320	-9.1	384	-2.7	448	3.7
1	-120.0	65	-63.0	129	-36.4	193	-23.6	257	-15.4	321	-9.0	385	-2.6	449	3.8
2	-118.0	66	-62.5	130	-36.2	194	-23.4	258	-15.3	322	-8.9	386	-2.5	450	3.9
3	-116.0	67	-62.0	131	-36.0	195	-23.2	259	-15.2	323	-8.8	387	-2.4	451	4.0
4	-114.0	68	-61.5	132	-35.8	196	-23.0	260	-15.1	324	-8.7	388	-2.3	452	4.1
5	-112.0	69	-61.0	133	-35.6	197	-22.8	261	-15.0	325	-8.6	389	-2.2	453	4.2
6	-110.0	70	-60.5	134	-35.4	198	-22.6	262	-14.9	326	-8.5	390	-2.1	454	4.3
7	-108.0	71	-60.0	135	-35.2	199	-22.4	263	-14.8	327	-8.4	391	-2.0	455	4.4
8	-106.0	72	-59.5	136	-35.0	200	-22.2	264	-14.7	328	-8.3	392	-1.9	456	4.5
9	-104.0	73	-59.0	137	-34.8	201	-22.0	265	-14.6	329	-8.2	393	-1.8	457	4.6
10	-102.0	74	-58.5	138	-34.6	202	-21.8	266	-14.5	330	-8.1	394	-1.7	458	4.7
11	-100.0	75	-58.0	139	-34.4	203	-21.6	267	-14.4	331	-8.0	395	-1.6	459	4.8
12	-99.0	76	-57.5	140	-34.2	204	-21.4	268	-14.3	332	-7.9	396	-1.5	460	4.9
13	-98.0	77	-57.0	141	-34.0	205	-21.2	269	-14.2	333	-7.8	397	-1.4	461	5.0
14	-97.0	78	-56.5	142	-33.8	206	-21.0	270	-14.1	334	-7.7	398	-1.3	462	5.1
15	-96.0	79	-56.0	143	-33.6	207	-20.8	271	-14.0	335	-7.6	399	-1.2	463	5.2
16	-95.0	80	-55.5	144	-33.4	208	-20.6	272	-13.9	336	-7.5	400	-1.1	464	5.3
17	-94.0	81	-55.0	145	-33.2	209	-20.4	273	-13.8	337	-7.4	401	-1.0	465	5.4
18	-93.0	82	-54.5	146	-33.0	210	-20.2	274	-13.7	338	-7.3	402	-0.9	466	5.5
19	-92.0	83	-54.0	147	-32.8	211	-20.0	275	-13.6	339	-7.2	403	-0.8	467	5.6
20	-91.0	84	-53.5	148	-32.6	212	-19.9	276	-13.5	340	-7.1	404	-0.7	468	5.7
21	-90.0	85	-53.0	149	-32.4	213	-19.8	277	-13.4	341	-7.0	405	-0.6	469	5.8
22	-89.0	86	-52.5	150	-32.2	214	-19.7	278	-13.3	342	-6.9	406	-0.5	470	5.9
23	-88.0	87	-52.0	151	-32.0	215	-19.6	279	-13.2	343	-6.8	407	-0.4	471	6.0
24	-87.0	88	-51.5	152	-31.8	216	-19.5	280	-13.1	344	-6.7	408	-0.3	472	6.1
25	-86.0	89	-51.0	153	-31.6	217	-19.4	281	-13.0	345	-6.6	409	-0.2	473	6.2
26	-85.0	90	-50.5	154	-31.4	218	-19.3	282	-12.9	346	-6.5	410	-0.1	474	6.3
27	-84.0	91	-50.0	155	-31.2	219	-19.2	283	-12.8	347	-6.4	411	0.0	475	6.4
28	-83.0	92	-49.5	156	-31.0	220	-19.1	284	-12.7	348	-6.3	412	0.1	476	6.5
29	-82.0	93	-49.0	157	-30.8	221	-19.0	285	-12.6	349	-6.2	413	0.2	477	6.6
30	-81.0	94	-48.5	158	-30.6	222	-18.9	286	-12.5	350	-6.1	414	0.3	478	6.7
31	-80.0	95	-48.0	159	-30.4	223	-18.8	287	-12.4	351	-6.0	415	0.4	479	6.8
32	-79.5	96	-47.5	160	-30.2	224	-18.7	288	-12.3	352	-5.9	416	0.5	480	6.9
33	-79.0	97	-47.0	161	-30.0	225	-18.6	289	-12.2	353	-5.8	417	0.6	481	7.0
34	-78.5	98	-46.5	162	-29.8	226	-18.5	290	-12.1	354	-5.7	418	0.7	482	7.1
35	-78.0	99	-46.0	163	-29.6	227	-18.4	291	-12.0	355	-5.6	419	0.8	483	7.2
36	-77.5	100	-45.5	164	-29.4	228	-18.3	292	-11.9	356	-5.5	420	0.9	484	7.3
37	-77.0	101	-45.0	165	-29.2	229	-18.2	293	-11.8	357	-5.4	421	1.0	485	7.4
38	-76.5	102	-44.5	166	-29.0	230	-18.1	294	-11.7	358	-5.3	422	1.1	486	7.5
39	-76.0	103	-44.0	167	-28.8	231	-18.0	295	-11.6	359	-5.2	423	1.2	487	7.6
40	-75.5	104	-43.5	168	-28.6	232	-17.9	296	-11.5	360	-5.1	424	1.3	488	7.7
41	-75.0	105	-43.0	169	-28.4	233	-17.8	297	-11.4	361	-5.0	425	1.4	489	7.8
42	-74.5	106	-42.5	170	-28.2	234	-17.7	298	-11.3	362	-4.9	426	1.5	490	7.9
43	-74.0	107	-42.0	171	-28.0	235	-17.6	299	-11.2	363	-4.8	427	1.6	491	8.0
44	-73.5	108	-41.5	172	-27.8	236	-17.5	300	-11.1	364	-4.7	428	1.7	492	8.1
45	-73.0	109	-41.0	173	-27.6	237	-17.4	301	-11.0	365	-4.6	429	1.8	493	8.2
46	-72.5	110	-40.5	174	-27.4	238	-17.3	302	-10.9	366	-4.5	430	1.9	494	8.3
47	-72.0	111	-40.0	175	-27.2	239	-17.2	303	-10.8	367	-4.4	431	2.0	495	8.4
48	-71.5	112	-39.8	176	-27.0	240	-17.1	304	-10.7	368	-4.3	432	2.1	496	8.5
49	-71.0	113	-39.6	177	-26.8	241	-17.0	305	-10.6	369	-4.2	433	2.2	497	8.6
50	-70.5	114	-39.4	178	-26.6	242	-16.9	306	-10.5	370	-4.1	434	2.3	498	8.7
51	-70.0	115	-39.2	179	-26.4	243	-16.8	307	-10.4	371	-4.0	435	2.4	499	8.8
52	-69.5	116	-39.0	180	-26.2	244	-16.7	308	-10.3	372	-3.9	436	2.5	500	8.9
53	-69.0	117	-38.8	181	-26.0	245	-16.6	309	-10.2	373	-3.8	437	2.6	501	9.0
54	-68.5	118	-38.6	182	-25.8	246	-16.5	310	-10.1	374	-3.7	438	2.7	502	9.1
55	-68.0	119	-38.4	183	-25.6	247	-16.4	311	-10.0	375	-3.6	439	2.8	503	9.2
56	-67.5	120	-38.2	184	-25.4	248	-16.3	312	-9.9	376	-3.5	440	2.9	504	9.3
57	-67.0	121	-38.0	185	-25.2	249	-16.2	313	-9.8	377	-3.4	441	3.0	505	9.4
58	-66.5	122	-37.8	186	-25.0	250	-16.1	314	-9.7	378	-3.3	442	3.1	506	9.5
59	-66.0	123	-37.6	187	-24.8	251	-16.0	315	-9.6	379	-3.2	443	3.2	507	9.6
60	-65.5	124	-37.4	188	-24.6	252	-15.9	316	-9.5	380	-3.1	444	3.3	508	9.7
61	-65.0	125	-37.2	189	-24.4	253	-15.8	317	-9.4	381	-3.0	445	3.4	509	9.8
62	-64.5	126	-37.0	190	-24.2	254	-15.7	318	-9.3	382	-2.9	446	3.5	510	9.9
63	-64.0	127	-36.8	191	-24.0	255	-15.6	319	-9.2	383	-2.8	447	3.6	511	10.0

6.2 Frequency Table

value	Frequency [Hz]	Display	value	Frequency [Hz]	Display	value	Frequency [Hz]	Display	value	Frequency [Hz]	Display	value	Frequency [Hz]	Display	value	Frequency [Hz]	Display
0	20	20.0 Hz	80	63	63.0 Hz	160	200	200 Hz	240	630	630 Hz	320	2000	2.00 kHz	400	6300	6.30 kHz
1	20.3	20.3 Hz	81	64	64.0 Hz	161	203	203 Hz	241	642	642 Hz	321	2030	2.03 kHz	401	6420	6.42 kHz
2	20.5	20.5 Hz	82	65	65.0 Hz	162	205	205 Hz	242	655	655 Hz	322	2050	2.05 kHz	402	6550	6.55 kHz
3	20.7	20.7 Hz	83	67	67.0 Hz	163	207	207 Hz	243	667	667 Hz	323	2080	2.08 kHz	403	6670	6.67 kHz
4	21	21.0 Hz	84	68	68.0 Hz	164	210	210 Hz	244	680	680 Hz	324	2100	2.10 kHz	404	6800	6.80 kHz
5	21.3	21.3 Hz	85	68.5	68.5 Hz	165	213	213 Hz	245	687	687 Hz	325	2140	2.14 kHz	405	6880	6.88 kHz
6	21.5	21.5 Hz	86	69	69.0 Hz	166	217	217 Hz	246	695	695 Hz	326	2170	2.17 kHz	406	6950	6.95 kHz
7	21.7	21.7 Hz	87	70	70.0 Hz	167	220	220 Hz	247	703	703 Hz	327	2200	2.20 kHz	407	7030	7.03 kHz
8	22	22.0 Hz	88	71	71.0 Hz	168	224	224 Hz	248	710	710 Hz	328	2240	2.24 kHz	408	7100	7.10 kHz
9	22.5	22.5 Hz	89	72	72.0 Hz	169	228	228 Hz	249	722	722 Hz	329	2280	2.28 kHz	409	7220	7.22 kHz
10	23	23.0 Hz	90	73	73.0 Hz	170	232	232 Hz	250	735	735 Hz	330	2320	2.32 kHz	410	7350	7.35 kHz
11	23.5	23.5 Hz	91	75	75.0 Hz	171	236	236 Hz	251	747	747 Hz	331	2360	2.36 kHz	411	7470	7.47 kHz
12	24	24.0 Hz	92	76	76.0 Hz	172	240	240 Hz	252	760	760 Hz	332	2400	2.40 kHz	412	7600	7.60 kHz
13	24.2	24.2 Hz	93	77	77.0 Hz	173	242	242 Hz	253	770	770 Hz	333	2430	2.43 kHz	413	7700	7.70 kHz
14	24.5	24.5 Hz	94	78	78.0 Hz	174	245	245 Hz	254	780	780 Hz	334	2450	2.45 kHz	414	7800	7.80 kHz
15	24.7	24.7 Hz	95	79	79.0 Hz	175	247	247 Hz	255	790	790 Hz	335	2470	2.47 kHz	415	7900	7.90 kHz
16	25	25.0 Hz	96	80	80.0 Hz	176	250	250 Hz	256	800	800 Hz	336	2500	2.50 kHz	416	8000	8.00 kHz
17	25.5	25.5 Hz	97	81	81.0 Hz	177	255	255 Hz	257	812	812 Hz	337	2550	2.55 kHz	417	8120	8.12 kHz
18	26	26.0 Hz	98	82	82.0 Hz	178	260	260 Hz	258	825	825 Hz	338	2600	2.60 kHz	418	8250	8.25 kHz
19	26.5	26.5 Hz	99	83	83.0 Hz	179	265	265 Hz	259	837	837 Hz	339	2650	2.65 kHz	419	8370	8.37 kHz
20	27	27.0 Hz	100	85	85.0 Hz	180	270	270 Hz	260	850	850 Hz	340	2700	2.70 kHz	420	8500	8.50 kHz
21	27.2	27.2 Hz	101	86	86.0 Hz	181	272	272 Hz	261	862	862 Hz	341	2730	2.73 kHz	421	8620	8.62 kHz
22	27.5	27.5 Hz	102	87	87.0 Hz	182	275	275 Hz	262	875	875 Hz	342	2750	2.75 kHz	422	8750	8.75 kHz
23	27.7	27.7 Hz	103	89	89.0 Hz	183	278	278 Hz	263	887	887 Hz	343	2770	2.77 kHz	423	8870	8.87 kHz
24	28	28.0 Hz	104	90	90.0 Hz	184	280	280 Hz	264	900	900 Hz	344	2800	2.80 kHz	424	9000	9.00 kHz
25	28.5	28.5 Hz	105	92	92.0 Hz	185	285	285 Hz	265	915	915 Hz	345	2850	2.85 kHz	425	9150	9.15 kHz
26	29	29.0 Hz	106	93	93.0 Hz	186	290	290 Hz	266	930	930 Hz	346	2900	2.90 kHz	426	9300	9.30 kHz
27	29.5	29.5 Hz	107	95	95.0 Hz	187	295	295 Hz	267	945	945 Hz	347	2950	2.95 kHz	427	9450	9.45 kHz
28	30	30.0 Hz	108	96	96.0 Hz	188	300	300 Hz	268	960	960 Hz	348	3000	3.00 kHz	428	9600	9.60 kHz
29	30.5	30.5 Hz	109	97	97.0 Hz	189	304	304 Hz	269	970	970 Hz	349	3040	3.04 kHz	429	9700	9.70 kHz
30	31	31.0 Hz	110	98	98.0 Hz	190	307	307 Hz	270	980	980 Hz	350	3070	3.07 kHz	430	9800	9.80 kHz
31	31.2	31.2 Hz	111	99	99.0 Hz	191	311	311 Hz	271	990	990 Hz	351	3110	3.11 kHz	431	9900	9.90 kHz
32	31.5	31.5 Hz	112	100	100 Hz	192	315	315 Hz	272	1000	1.00 kHz	352	3150	3.15 kHz	432	10000	10.0 kHz
33	32	32.0 Hz	113	101	101 Hz	193	321	321 Hz	273	1010	1.01 kHz	353	3210	3.21 kHz	433	10100	10.1 kHz
34	33	33.0 Hz	114	102	102 Hz	194	327	327 Hz	274	1020	1.02 kHz	354	3270	3.27 kHz	434	10300	10.3 kHz
35	33.5	33.5 Hz	115	103	103 Hz	195	333	333 Hz	275	1030	1.03 kHz	355	3340	3.34 kHz	435	10400	10.4 kHz
36	34	34.0 Hz	116	105	105 Hz	196	340	340 Hz	276	1050	1.05 kHz	356	3400	3.40 kHz	436	10500	10.5 kHz
37	34.5	34.5 Hz	117	106	106 Hz	197	344	344 Hz	277	1070	1.07 kHz	357	3440	3.44 kHz	437	10700	10.7 kHz
38	35	35.0 Hz	118	107	107 Hz	198	347	347 Hz	278	1080	1.08 kHz	358	3470	3.47 kHz	438	10900	10.9 kHz
39	35.5	35.5 Hz	119	108	108 Hz	199	351	351 Hz	279	1100	1.10 kHz	359	3510	3.51 kHz	439	11100	11.1 kHz
40	36	36.0 Hz	120	110	110 Hz	200	355	355 Hz	280	1120	1.12 kHz	360	3550	3.55 kHz	440	11200	11.2 kHz
41	36.5	36.5 Hz	121	112	112 Hz	201	361	361 Hz	281	1140	1.14 kHz	361	3610	3.61 kHz	441	11400	11.4 kHz
42	37	37.0 Hz	122	115	115 Hz	202	367	367 Hz	282	1160	1.16 kHz	362	3670	3.67 kHz	442	11600	11.6 kHz
43	37.5	37.5 Hz	123	118	118 Hz	203	374	374 Hz	283	1180	1.18 kHz	363	3750	3.75 kHz	443	11800	11.8 kHz
44	38	38.0 Hz	124	120	120 Hz	204	380	380 Hz	284	1200	1.20 kHz	364	3800	3.80 kHz	444	12000	12.0 kHz
45	38.5	38.5 Hz	125	121	121 Hz	205	385	385 Hz	285	1210	1.21 kHz	365	3850	3.85 kHz	445	12200	12.2 kHz
46	39	39.0 Hz	126	122	122 Hz	206	390	390 Hz	286	1220	1.22 kHz	366	3900	3.90 kHz	446	12300	12.3 kHz
47	39.5	39.5 Hz	127	123	123 Hz	207	395	395 Hz	287	1240	1.24 kHz	367	3950	3.95 kHz	447	12400	12.4 kHz
48	40	40.0 Hz	128	125	125 Hz	208	400	400 Hz	288	1250	1.25 kHz	368	4000	4.00 kHz	448	12500	12.5 kHz
49	40.5	40.5 Hz	129	127	127 Hz	209	408	408 Hz	289	1280	1.28 kHz	369	4070	4.07 kHz	449	12800	12.8 kHz
50	41	41.0 Hz	130	130	130 Hz	210	415	415 Hz	290	1300	1.30 kHz	370	4150	4.15 kHz	450	13000	13.0 kHz
51	42	42.0 Hz	131	133	133 Hz	211	422	422 Hz	291	1330	1.33 kHz	371	4220	4.22 kHz	451	13300	13.3 kHz
52	43	43.0 Hz	132	136	136 Hz	212	430	430 Hz	292	1360	1.36 kHz	372	4300	4.30 kHz	452	13600	13.6 kHz
53	43.5	43.5 Hz	133	137	137 Hz	213	435	435 Hz	293	1370	1.37 kHz	373	4350	4.35 kHz	453	13700	13.7 kHz
54	44	44.0 Hz	134	138	138 Hz	214	440	440 Hz	294	1380	1.38 kHz	374	4400	4.40 kHz	454	13800	13.8 kHz
55	44.5	44.5 Hz	135	139	139 Hz	215	445	445 Hz	295	1390	1.39 kHz	375	4450	4.45 kHz	455	13900	13.9 kHz
56	45	45.0 Hz	136	140	140 Hz	216	450	450 Hz	296	1400	1.40 kHz	376	4500	4.50 kHz	456	14000	14.0 kHz
57	45.5	45.5 Hz	137	143	143 Hz	217	457	457 Hz	297	1430	1.43 kHz	377	4570	4.57 kHz	457	14300	14.3 kHz
58	46	46.0 Hz	138	146	146 Hz	218	465	465 Hz	298	1460	1.46 kHz	378	4650	4.65 kHz	458	14600	14.6 kHz
59	47	47.0 Hz	139	149	149 Hz	219	472	472 Hz	299	1490	1.49 kHz	379	4730	4.73 kHz	459	14900	14.9 kHz
60	48	48.0 Hz	140	152	152 Hz	220	480	480 Hz	300	1520	1.52 kHz	380	4800	4.80 kHz	460	15200	15.2 kHz
61	48.5	48.5 Hz	141	154	154 Hz	221	485	485 Hz	301	1540	1.54 kHz	381	4850	4.85 kHz	461	15400	15.4 kHz
62	49	49.0 Hz	142	156	156 Hz	222	490	490 Hz	302	1560	1.56 kHz	382	4900	4.90 kHz	462	15600	15.6 kHz
63	49.5	49.5 Hz	143	158	158 Hz	223	495	495 Hz	303	1580	1.58 kHz	383	4950	4.95 kHz	463	15800	15.8 kHz
64	50	50.0 Hz	144	160	160 Hz	224	500	500 Hz	304	1600	1.60 kHz	384	5000	5.00 kHz	464	16000	16.0 kHz
65	50.5	50.5 Hz	145	162	162 Hz	225	507	507 Hz	305	1630	1.63 kHz	385	5080	5.08 kHz	465	16300	16.3 kHz
66	51	51.0 Hz	146	165	165 Hz	226	515	515 Hz	306	1650	1.65 kHz	386	5150	5.15 kHz	466	16500	16.5 kHz
67	52	52.0 Hz	147	167	167 Hz	227	522	522 Hz	307	1680	1.68 kHz	387	5220	5.22 kHz	467	16800	16.8 kHz
68	53	53.0 Hz	148	170	170 Hz	228	530	530 Hz	308	1700	1.70 kHz	388	5300	5.30 kHz	468	17000	17.0 kHz
69	53.5	53.5 Hz	149	172	172 Hz	229	538	538 Hz	309	1730	1.73 kHz	389	5380	5.38 kHz	469	17300	17.3 kHz
70	54	54.0 Hz	150	175	175 Hz	230	545	545 Hz	310	1750	1.75 kHz	390	5450	5.45 kHz	470	17500	17.5 kHz
71	55	55.0 Hz	151	177	177 Hz	231	552	552 Hz	311	1780	1.78 kHz	391	5530	5.53 kHz	471	17800	17.8 kHz
72	56	56.0 Hz	152	180	180 Hz	232	560	560 Hz	312	1800	1.80 kHz	392	5600	5.60 kHz	472	18000	18.0 kHz
73	57	57.0 Hz	153	183	183 Hz	233	570	570 Hz	313	1830	1.83 kHz	393	5700	5.70 kHz	473	18300	18.3 kHz
74	58	58.0 Hz	154	186	186 Hz	234	580	580 Hz	314	1860	1.86 kHz	394	5800	5.80 kHz	474	18600	18.6 kHz
75	59	59.0 Hz	155	189	189 Hz	235	590	590 Hz	315	1890	1.89 kHz	395	5900	5.90 kHz			

6.3 Q Value Table

#	Quality
0	0.3
1	0.35
2	0.41
3	0.47
4	0.55
5	0.64
6	0.75
7	0.87
8	1
9	1.2
10	1.4
11	1.6
12	1.9
13	2.2
14	2.5
15	3
16	3.5
17	4
18	4.5
19	5
20	6
21	7
22	8.4
23	10
24	12
25	14
26	16
27	19
28	22
29	25
30	30
31	60

6.4 EQ Gain Table

#	Gain	#	Gain	#	Gain
0	-18	25	-5.5	50	7
1	-17.5	26	-5	51	7.5
2	-17	27	-4.5	52	8
3	-16.5	28	-4	53	8.5
4	-16	29	-3.5	54	9
5	-15.5	30	-3	55	9.5
6	-15	31	-2.5	56	10
7	-14.5	32	-2	57	10.5
8	-14	33	-1.5	58	11
9	-13.5	34	-1	59	11.5
10	-13	35	-0.5	60	12
11	-12.5	36	0	61	12.5
12	-12	37	0.5	62	13
13	-11.5	38	1	63	13.5
14	-11	39	1.5	64	14
15	-10.5	40	2	65	14.5
16	-10	41	2.5	66	15
17	-9.5	42	3	67	15.5
18	-9	43	3.5	68	16
19	-8.5	44	4	69	16.5
20	-8	45	4.5	70	17
21	-7.5	46	5	71	17.5
22	-7	47	5.5	72	18
23	-6.5	48	6		
24	-6	49	6.5		

6.5 Input Gain Table

Value	Mic [dB]	Value	Mic [dB]	Value	Mic [dB]
0	0	11	11	21	21
1	1	12	12	22	22
2	2	13	13	23	23
3	3	14	14	24	24
4	4	15	15	25	25
5	5	16	16	26	26
6	6	17	17	27	27
7	7	18	18	28	28
8	8	19	19	29	29
9	9	20	20	30	30
10	10	21	21		

6.6 Transfer data type

No	Item	Description	Type	Value	Value Description	Remarks
1	kind	Transfer data type	string	p1 to p16	Preset 1 to 16	
2				log	Log file	

6.7 Attenuation Level Table

#	Display
0	$-\infty$
1	-30dB
2	-29dB
3	-28dB
4	-27dB
5	-26dB
6	-25dB
7	-24dB
8	-23dB
9	-22dB
10	-21dB
11	-20dB
12	-19dB
13	-18dB
14	-17dB
15	-16dB
16	-15dB
17	-14dB
18	-13dB
19	-12dB
20	-11dB
21	-10dB
22	-9dB
23	-8dB
24	-7dB
25	-6dB
26	-5dB
27	-4dB
28	-3dB

6.8 Version correspondence table

Document ver.	ATND1061DAN FW Version							ATND1061LK FW Version						Revision history
	1.0.0	1.0.4	1.1.0	1.2.0	1.3.0	1.3.1	1.4.0	1.0.0	1.1.0	1.2.0	1.3.0	1.3.1	1.4.0	
1.0	○	○	○	○	○	○	○	×	×	×	×	×	×	First edition
2.0	×	○	○	○	○	○	○	×	×	×	×	×	×	Changed some commands.
3.0	×	○	○	○	○	○	○	○	○	○	○	○	○	Supported LK. Changed some commands.
4.0	×	×	○	○	○	○	○	×	○	○	○	○	○	Added camera sync.
5.0	×	×	×	○	○	○	○	×	×	○	○	○	○	Added Voice Lift.
6.0	×	×	×	×	○	○	○	×	×	×	○	○	○	Corrected the camera port number. Added Voice Lift Output Select and Room Type.
7.0	×	×	×	×	×	○	○	×	×	×	×	○	○	Changed the condition for the validity of camera port number.
8.0	×	×	×	×	×	×	○	×	×	×	×	×	○	Added the Talker Position Acquisition command and corrected other typos.

株式会社オーディオテクニカ

〒194-8666 東京都町田市西成瀬2-46-1
www.audio-technica.co.jp

Audio-Technica Corporation

2-46-1 Nishi-naruse, Machida, Tokyo 194-8666, Japan
www.audio-technica.com
©2025 Audio-Technica Corporation
Global Support Contact: www.at-globalsupport.com

ver.1 2021.12.15
ver.7 2025.06.01